

PAT-4 LINE STAGE REPLACEMENT COMPONENTS ASSEMBLY MANUAL



© 2015-2023 AkitikA, LLC
All rights reserved
Revision 1p05 January 19, 2023

Table of Contents

Table of Contents	2
Table of Figures	2
Section 1: About This Manual	3
Who Should Attempt these Projects?	4
Important Safety Notes	4
Tools and Supplies you'll Need	4
Recommended Solder	4
Section 2: Removing the old and installing the New Components	5
Project Overview	5
Preparing to Remove the Circuit Boards	5
Replacing the Components	6
Installing the DRD4 Kit	6
Section 3: Putting it All Back Together	7
Inspection and Preliminary Reassembly	7
Final Sanity Checks	7
Final Assembly	7
Appendix 1: The Toothpick Trick	9
Appendix 2: First Class De-soldering	9

Table of Figures

Figure 1-Showing replacement of high level stage components	8
---	---

Section 1: About This Manual

This manual gives the information you need to install the Line Stage Replacement Component upgrade to the Dynaco PAT-4 Preamp. You'll replace 5% and 10% tolerance resistors with 1% resistors. This centers up the design and extracts the maximum performance from your PAT-4. In addition, these new metal film resistors typically are much quieter and have lower distortion than the original carbon composition resistors.

As of this writing, the following other PAT-4 upgrades are available from Updatemydynaco, a division of Akitika LLC:

- Blue Light Kit (BLUE)
- Line Amp Distortion Reducer (DRD4)
- Tone Control Switch (TCS)
- Electronically Regulated Power Supply (PAT4PWR)
- Phono Upgrade Kit (PAT4LP)

The blue light kit changes the light in the power switch from original orange to beautiful blue.

The Line Amp Distortion Reducer drops the distortion of the Line Amp by a factor of ten. The Line Amp is the stage that includes the volume and tone controls. All sound from the preamp passes through the Line Amp. This upgrade makes everything played through the PAT-4 sound better. It is a perfect complement to the Line Stage Replacement Component upgrade.

The Tone Control Switch replaces the existing Hi Filter switch with a two position rotary switch. In the OFF position, the tone controls are disabled. In the 15 position, tone controls maintain their normal function. After this modification, the other two positions of the HI FILTER switch (10 and 7) are not available. You can install optional resistors (not provided) that drop the Line Amp gain when the tone controls are off. This drops the gain of the Line Amp, increasing Signal to Noise Ratio.

The regulated power supply kit replaces the original diodes, 3-section cap, and resistors with an electronically regulated power supply. When you install the PAT4PWR supply, you dramatically reduce the hum in the PAT-4. It mounts conveniently in existing holes in the PAT-4.

The phono upgrade kit decreases the phono stage noise by between 4 and 8 dB. It also smooths out the input impedance, making it very near the ideal 47K Ohms. Finally, it converts the preamp to support 3 phono inputs while eliminating input selector switching noise.

These upgrades can be installed in any combination, but the phono upgrade kit requires the PAT4PWR supply to be installed.

Who Should Attempt these Projects?

You can build this kit if you can:

1. solder (using normal rosin core solder and a soldering iron),
2. use simple hand tools like screwdrivers, wire cutters, and pliers, and
3. Read and follow directions.

It helps if you:

1. know a bit about electronics, or
2. have a friend who knows a bit about electronics
3. can get to YouTube to watch a few helpful videos about the assembly process (not available as of this version of the manual)

Important Safety Notes

By purchasing, using, or assembling this kit, you have agreed to hold AkitikA, LLC harmless for any injuries you may receive in its assembly and/or use. To prevent injuries:

- Wear safety glasses when soldering to prevent eye injuries.
- Always unplug the power before working on the equipment.
- Large capacitors hold lots of energy for a long time. Before you put your hands into the equipment:
 - Pull the AC plug!
 - Wait 1 full minute for the capacitors to discharge!
- Remove jewelry and rings from your hands and wrists, or anything that might dangle into the amplifier.
- If working in the amplifier, keep one hand in your pocket, especially if you're near the power supply or power supply wires. This can prevent serious shocks.
- Build with a buddy nearby. If you've ignored all the previous advice, they can dial 911 or get you to the hospital.

Tools and Supplies you'll Need

You'll need the following tools:

1. flat blade screwdrivers for #4 and #6 screws
2. needle nose pliers (helpful, but not strictly necessary)
3. pencil type soldering iron of 25 to 50 Watts (no huge honking soldering guns or blowtorches)
4. wire cutters and strippers
5. de-soldering tools (see the Appendix 1 and Appendix 2)
6. Magnifying glass, if you're over 42!
7. A multi-meter for measuring Ohms and DC volts is handy, but not strictly necessary

Recommended Solder

The kit must be assembled with 60/40 *Rosin Core* solder. The recommended diameter is 0.032 inches. Among many such sources of solder, I have used Radio Shack part number 64-009. It contains 8 oz. of solder, which is *much* more than you'll need for this kit.

Section 2: Removing the old and installing the New Components

Project Overview

Broadly, the project consists of the following steps:

1. Labeling, then de-soldering all the wires from each circuit board.
2. Replacing a number of components with the supplied components.
3. Re-attaching the wires to the circuit boards (with a few modifications).
4. Reassembling the preamp.

Preparing to Remove the Circuit Boards

1. Disconnect the PAT-4 from your music system.
2. Unplug the power cord and allow the preamp to sit for one minute before moving on.

Caution: Be sure that the preamp power is unplugged! 120 VAC can be lethal! 240 VAC can be lethal!

3. Remove the 4 screws that hold the cover in place, 2 on the left side and 2 on the right side.
4. Lift the cover straight up and set it aside in a safe place.
5. The kit is supplied with two sets of number labels, one for the right channel, and one for the left channel.
6. Mark all the wires that connect to the left channel (it's the one closer to the back of the chassis) PCB using the supplied labels. These labels have an eyelet number, and the letter B, for back. Make sure that the label numbers match the eyelet numbers etched in the copper traces on the solder side of the PCB. This will help you get the preamp back together after the modifications.
7. Desolder all the wires from the left channel PCB after they are labeled. Be careful not to put too much stress on the selector switch.
8. Mark all the wires that connect to the right channel (it's the one closer to the front of the chassis) PCB using the supplied labels. These labels have an eyelet number, and the letter F, for Front. Make sure that the label numbers match the eyelet numbers etched in the copper traces on the solder side of the PCB. This will help you get the preamp back together after the modifications.
9. De-solder all the wires from the right channel PCB after they are labeled. Don't put too much stress on the selector switch as you remove these wires.
10. Prepare to remove the two PCB's and the bracket that holds them in place by carefully dressing the wires out of the way,
11. Remove the two 6-32 nuts, lock washers, and screws that hold the U-shaped brackets that retain the circuit boards to the bottom of the chassis.
12. Remove the assembly of the brackets and the two PCB's from the chassis.
13. Remove the 4-40 hardware that holds the PCB's to the U-shaped bracket. Keep track of the lock washers, and remove them so they don't float around inside the preamp or on the PC board.
14. Once both boards are removed, clear the solder from the numbered eyelet holes. If you have official de-soldering equipment, use it. If you don't, you may want to

use the Toothpick Trick (see Appendix 1 and 2) to clear the solder from these eyelets. Doing so will make reassembly much easier. Check for daylight visible through all the holes, and/or that they will pass a piece of bare hook-up wire.

Replacing the Components

Following the table below, desolder each original component indicated and replace it with the new component. In many cases, the new components are smaller. Use a meter to verify the correct resistor values prior to installation. Refer to Figure 1 located on page 8 for the location and polarity (electrolytic capacitors) of the components that you will replace.

Designation	Original Value, description	Color code or marking (new components)	Done Left (✓)	Done Right (✓)
Resistors				
R15	4700	Yellow, violet, black, brown, brown		
R21	4700	Yellow, violet, black, brown, brown		
R16	390	Orange, white, black, black, brown		
R17	68K0	Blue, gray, black, red, brown		
R18	33	Orange, orange, black, gold, brown		
R19	120K	Brown, red, black, orange, brown		
R20	620, 1 Watt	620Ω		
R22	68	Blue, gray, black, gold, brown		
R23	560	Green, blue, black, black, brown		
Film Capacitor (non-polar)				
C13	5 μF, 15V	4.7 μF, 63V, marked 475K		
Electrolytic Capacitors (watch polarity)				
C15	320 μF, 6V	330 μF, 16V watch polarity!		
C16	50 μF, 25V	47 μF, 35 V watch polarity!		
C21	50 μF, 25V	47 μF, 35 V watch polarity!		
Transistor				
Q3	BC109B	MPSA18 watch pinout! 2N5088 in Rev 4 kit.		

Component variation notes

1. The rated voltage of the electrolytic capacitors may differ slightly from the table values above, but so long as the capacitance values match, all is well.
2. Rev 4 of the kit uses the 2N5088 instead of the MPSA18.
3. Rev 4 uses a different shape of C13. Leave the leads full length until the cap is installed. You may choose to insulate the leads to avoid shorting to other components.

Installing the DRD4 Kit

If you purchased a DRD4 Kit, this is the perfect time to install it. See the DRD4 manual for details. The special DRD4 transistor and heat sink replaces the stock transistor Q4 and its star-shaped heat sink.

Section 3: Putting it All Back Together

Inspection and Preliminary Reassembly

Inspect your work for good solder joints and freedom from solder bridges. Touch up any questionable connections now. It will be painful to have to disassemble things to repair something later. Verify that the eyelets along the tops of the boards are free of solder and are ready to accept the labeled wires.

Attach the PC boards to the U-shaped bracket. Use the original 4-40 hardware unless you have new hardware from a purchase of the PAT4LP kit. Screw the assembly of PC-boards and U-shaped bracket back into the PAT-4 chassis. Use the original 6-32 screws hardware unless you have new hardware from the PAT4LP kit.

Use the labels as a guide. Re-insert and solder all of the labeled wires to either the front or back PCB as indicated by the labels.

Final Sanity Checks

Here are a few last tests before you reconnect your PAT-4 to your music system. With the top still off, plug in the AC mains. Turn on the power switch. Set your meter to DC volts. Connect one lead of the meter to ground.

<i>Be careful! These steps are performed with the power connected and turned on!</i>	Done ✓	Done ✓
The voltage on eyelet 4 of both preamp PCB's should measure between 16 and 20 volts DC (with respect to ground). (It should be between 17 and 18 volts if you've installed the PAT4PWR kit).	<input type="checkbox"/>	<input type="checkbox"/>
The voltage on eyelet 12 of both preamp PCB's should measure between 32 and 44 volts DC (with respect to ground). (It should be between 36 and 40 Volts if you've installed the PAT4PWR kit).	<input type="checkbox"/>	<input type="checkbox"/>

Final Assembly

Here are the final assembly steps.

- Turn off the power!
- **Remove the AC plug from the wall socket!**
- Replace the preamp's cover.
- Reinstall the four screws that hold the cover in place.
- Reinstall the PAT-4 to your music system.

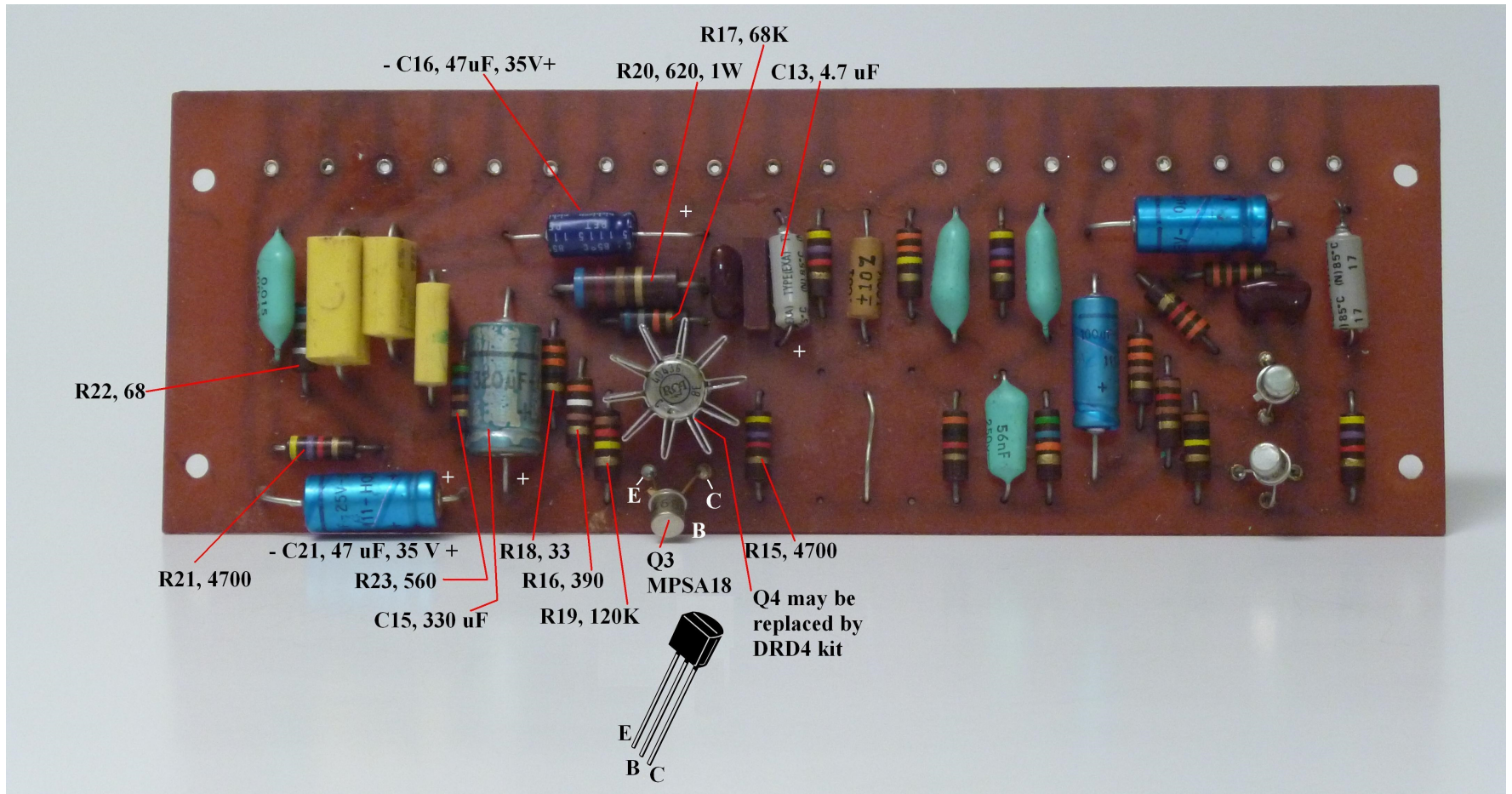

Figure 1-Showing replacement of high level stage components

Note: 2N5088 is supplied rather than MPSA18 in Rev 4 and above kits.

Appendix 1: The Toothpick Trick

This appendix describes an easy way to clear the solder from a hole in the PCB. It can also be used to clear the solder from terminals on pots or jacks. Doing so makes it easier to install a new component, or reinstall wires that were temporarily removed to allow access to some other component.

All you'll need is a soldering iron and some toothpicks with sharp points. The diameter of the pointed part of the toothpick must be smaller than the diameter of the hole that you're trying to clear.

Heat the solder land on the component side of the board until the solder flows. Insert the toothpick from the component side of the board while pushing and twisting the toothpick. If the solder has melted, the toothpick should push through the board, displacing the solder. Remove the soldering iron, but let the toothpick remain in the hole until the solder has solidified. Now remove the toothpick. There should be a hole through the solder sufficiently large to allow you to insert the component lead or wire.

Sometimes, a bit of the toothpick will break off in the hole. If this happens, use a stiff piece of wire to push the toothpick fragment out of the hole.

Appendix 2: First Class De-soldering

De-soldering can be easy if you have the right tools. Through the years, I've used a number of "make-do" methods:

- The toothpick trick – not bad for clearing a hole if the diameter is big enough.
- Sold-a-pult- these spring loaded, one shot solder vacuums are a step in the right direction, but can't supply both heat and vacuum action simultaneously. Some people cut a v-shaped hole in the tip to poke the soldering iron through, but it's still a bit hit or miss, and frustrating.
- Solder wick- this is copper braid that you heat up in connection with the joint. The idea is that the solder wicks into the copper braid, away from the joint. It's still slow and frustrating, and takes so much heat that you worry about the board.

At some point, you'll decide that you deserve a better way to desolder, and you'll buy a heat source with a built in continuous vacuum pump. Big industrial units can cost many hundreds of dollars. Here's the best value I've found so far, the Hakko 808. I bought mine for about \$180, and it's worth every penny. Often when I de-solder components, the action is so clean that they just fall out of the board.

Once you've treated yourself to a real de-soldering tool like the Hakko 808, you'll wonder why you waited so long.