

PAT-4 PREAMP RENEWAL CIRCUIT BOARDS ASSEMBLY AND INSTALLATION MANUAL

© 2020-2023 Akitika, LLC
All rights reserved
Revision 1p21 May 24, 2023

Table of Contents

Table of Contents	2
Table of Figures	2
Section 1: About This Manual	4
Who Should Attempt these Projects?	4
Tools and Supplies You'll Need	5
Recommended Solder	5
Project Overview	5
Important Safety Notes	5
Section 2: About the PAT4 Renewal Circuit Boards.....	6
Building the PAT4RENEW Circuit Boards	6
Component Order.....	7
Install the Resistors	7
Prepare and Add Shielded Cables to the Inputs.....	13
Installing the Assembled Circuit Boards	14
Preparing to Install the Assembled PAT4PPR Circuit Board.....	14
Prerequisites	14
PAT-4 Power Modifications, PAT4PWR Rev B.....	15
PAT-4 Power Modifications, PAT4PWR Rev C.....	15
Removing the original boards	16
Modify the PAT-4 Wiring for PHONO plus 5 High-Level inputs	17
Clear away a few old wires	20
Install the Boards onto the Mounting Brackets.....	20
Connect the PHONO LOW RCA Jacks.....	21
Installing Power Wires.....	21
Reconnecting the Rest of the labeled wires	23
If you have already installed the upgraded PAT4 Selector Kit	24
Inspection and Preliminary Reassembly	24
Final Sanity Checks	24
Prepare to Reconnect your PAT-4 to your Music System.....	24
Record Playing Reminders	25
Schematics	26
Specifications.....	29
Phono Stage	29
Line Stage	30
Appendix 1: The Toothpick Trick	30
Appendix 2 - Preparing a Shielded Cable End	31
Appendix 3 - Resistor Color Code.....	33

Table of Figures

Figure 1-Component side of the PAT4RENEW PCB before loading (RevB Ver8)	6
Figure 2-Component side of the PAT4RENEW PCB before loading (RevC Ver1)	6
Figure 3-Assembled Single Channel (Rev B Ver8).....	8
Figure 4-Assembled Single Channel (Rev C Ver 1).....	8
Figure 5-Installing resistors	9

Figure 6-Proper height for transistor installation..... 12
Figure 7-Closeup of LED, note anode is longer 13
Figure 8-Shielded cable installation (right channel shown here)..... 14
Figure 9-Adding the power good wire to D8’s cathode 15
Figure 10-Back Panel wire cuts and ground additions 17
Figure 11-back panel after previous set of tasks and addition of 0.01 uF caps 18
Figure 12-Original switch wiring..... 19
Figure 13-Re-use the original 4-40 screws to re-attach mounting brackets to the PCBs . 21
Figure 14-Schematic of the PAT4Renewal Board..... 26
Figure 15-DC voltages on the line stage..... 27
Figure 16-PAT4 with renewal boards installed 28
Figure 17- Shield wire end prep completed (right channel) 32
Figure 18-demonstrating the resistor color code 33

Section 1: About This Manual

This manual gives the information you need to build and install the PAT-4 Preamp Renewal Circuit boards (PAT4RENEW). This kit provides the most straightforward way to update and improve the performance of your PAT-4 preamp. Compared to the original, this upgrade has:

- Lower noise.
- Lower distortion.
- A quieter, more accurate phono preamp (moving magnet cartridge).
- Much higher overload capability in the phono preamp.
- Built-in ultra-low frequency filter for the phono preamp.
- Built in de-click resistors and eyelets to make the tone control bypass switch (sold separately) installation cleaner.
- 1% metal film resistors for better linearity, lower noise, and more accurate channel-to-channel matching.
- Power-up/power-down transient suppressing relays and time delays to avoid nasty noises with power up/down.

The preamp renewal circuit boards require the installation of the Updatemydynaco PAT4PWR power supply board. There are also some changes that you'll make to the power supply board.

This upgrade does not include provisions for SPECIAL and TAPE HEAD as low-level inputs. Instead, we convert these inputs to additional high-level inputs. The result is a preamp with 5 high-level inputs and 1 phono input.

Updatemydynaco makes the following other kits that you may choose to add to your improved PAT-4 preamp:

- Blue Light Kit (BLUE)
- Tone Control Switch (TCS)
- Toroidal transformer for PAT4 (PAT4X)
- PAT4 gold-plated RCA replacement jacks with great ground (PAT4RCAGG)
- PAT4SEL, an upgraded replacement for the selector switch.
- PAT4CSC, a kit that replaces the chassis capacitors with new film caps.

Who Should Attempt these Projects?

You can build this kit if you can:

1. solder (using normal rosin core solder and a soldering iron),
2. use simple hand tools like screwdrivers, wire cutters, and pliers, and
3. Read and follow directions.

It helps if you:

1. know a bit about electronics, or
2. have a friend who knows a bit about electronics

3. can get to YouTube to watch a few helpful videos about the assembly process (not available as of this version of the manual)

Tools and Supplies You'll Need

You'll need the following tools:

1. flat blade screwdrivers for #4 and #6 screws, #2 Philips head screwdriver
2. needle nose pliers (helpful, but not strictly necessary)
3. pencil type soldering iron of 25 to 50 Watts (no huge honking soldering guns or blowtorches)
4. wire cutters and strippers
5. de-soldering tools (see the Appendix 1 and Appendix 2)
6. Magnifying glass, if you're over 42!
7. A multi-meter for measuring Ohms and DC volts is strongly recommended.
Measuring each resistor to confirm the color code reading dramatically cuts down on assembly mistakes.

Recommended Solder

The kit must be assembled with 60/40 or 63/37 Rosin Core solder. The recommended diameter is 0.031 - 0.032 inches.

Project Overview

Broadly, the project consists of the following steps:

1. Building the PAT4RENEW circuit boards.
2. Building and/or modifying the PAT4PWR power supply.
3. Removing the old boards and labeling the wires.
4. Modifying the chassis wiring.
5. Installing the new boards.
6. Reassembling the preamp.

Important Safety Notes

By purchasing, using, or assembling this kit, you have agreed to hold AkitikA, LLC harmless for any injuries you may receive in its assembly and/or use. To prevent injuries:

- Wear safety glasses when soldering to prevent eye injuries.
- Always unplug the power before working on the equipment.
- Large capacitors hold lots of energy for a long time. Before you put your hands into the equipment:
 - Pull the AC plug!
 - Wait 1 full minute for the capacitors to discharge!
- Remove jewelry and rings from your hands and wrists, or anything that might dangle into the amplifier.
- If working in the amplifier, keep one hand in your pocket, especially if you're near the power supply or power supply wires. This can prevent serious shocks.
- Build with a buddy nearby. If you've ignored all the previous advice, they can dial 911 or get you to the hospital.

Section 2: About the PAT4 Renewal Circuit Boards

Building the PAT4RENEW Circuit Boards

This section details the process of building the PAT4RENEW circuit boards. We start with an overview on this page. The specifics you need to start building begin on the next page. Figure 1 shows the component locations on the PCB.

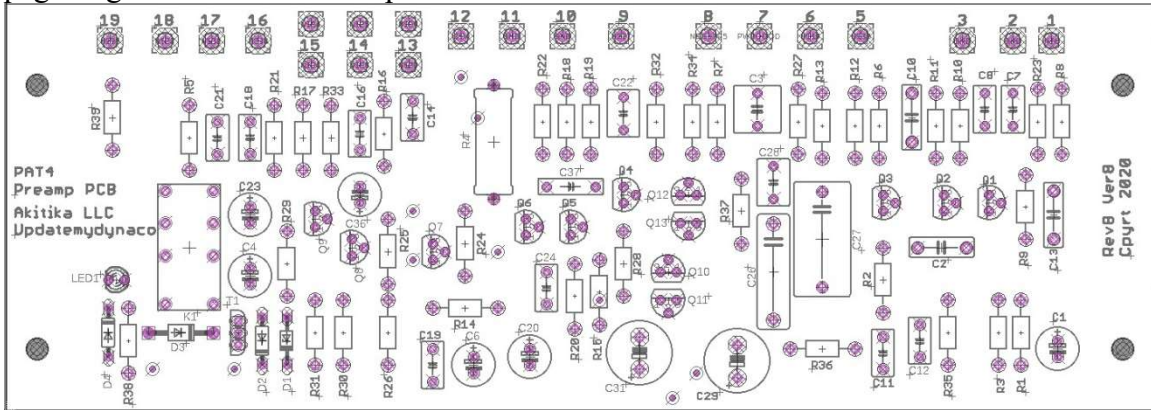

Figure 1-Component side of the PAT4RENEW PCB before loading (RevB Ver8)

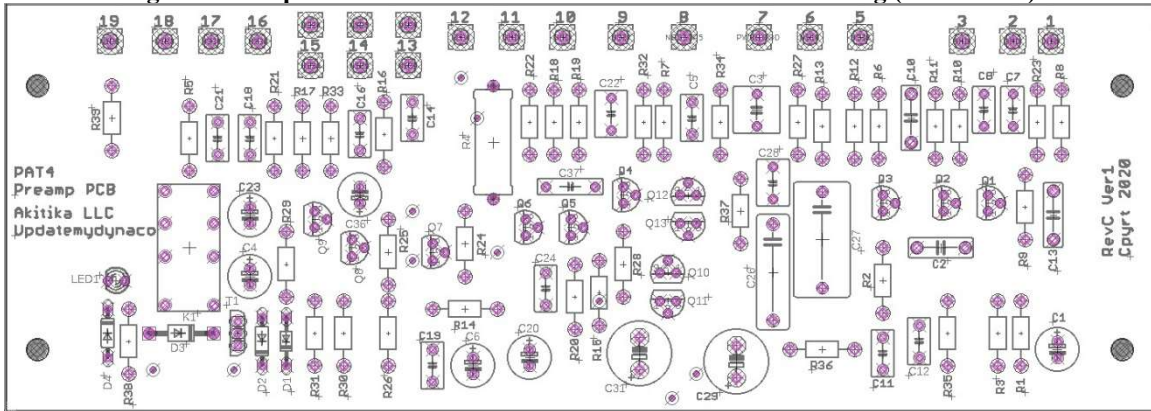

Figure 2-Component side of the PAT4RENEW PCB before loading (RevC Ver1)

Begin by carefully emptying the contents of the parts envelope into a broad soup bowl, as shown below. In general, you'll start with the components that lay closest to the board, working your way towards the taller components. You will:

1. Install the resistors
2. Install the capacitors
3. Install the transistors
4. Install the relay



Component Order

You'll notice that the component designations in the directions don't go exactly in order. We have grouped them so that all components with the same value appear together. This makes assembly easier. You'll find in the parts kit that similar parts, e.g. 3 1K resistors, are typically (though not always) taped together.

Install the Resistors

In general, you install the resistors by placing the body on silk screen side of the board, and the leads through the indicated holes. Bend the leads over on the back of the board to keep the resistors from falling out until you solder them in place. Try to bend the leads in a direction that won't lead to solder bridges between traces that should remain disconnected.

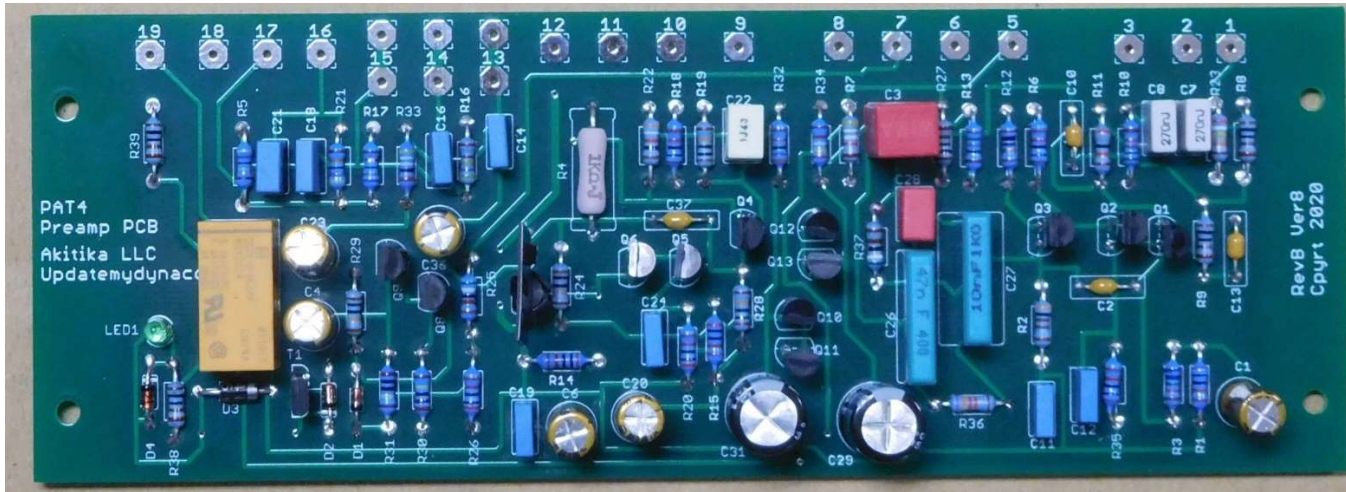

Figure 3-Assembled Single Channel (Rev B Ver8)

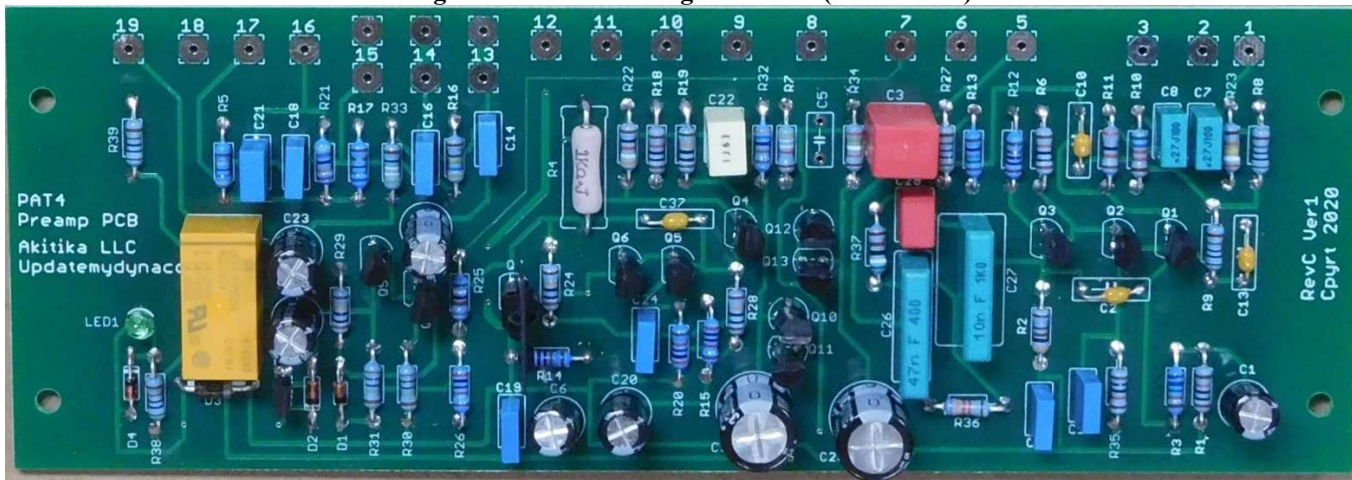

Figure 4-Assembled Single Channel (Rev C Ver 1)

Note that C5 is not populated.

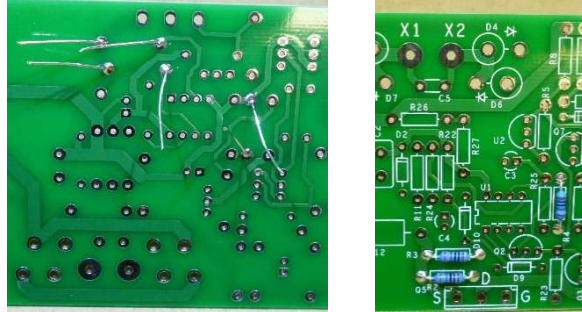

Figure 5-Installing resistors

We recommend the following procedure:

1. Insert all the resistors of the same value, e.g. R19 and R24.
2. Bend the leads as described above.
3. Solder the leads on the back of the board.
4. Clip the leads.

Track your progress by placing a checkmark in the done column as you install each resistor. Check resistor values with a meter and by reading the color code¹. Orient the resistor with the fat brown band on the right, then you can read both the Color Code column and the resistor from left to right. The majority of assembly errors are of the type where a 24R9 Ohm (24.9 Ohm) resistor gets swapped for a 24K9 Ohm (24,900 Ohm), so checking the resistor two ways is a great way to avoid this error.

The holes for the 1/4W resistor leads are spaced at 0.4". If you have a lead bender, this will speed up and neaten your assembly. A lead bender is not required. You will install all the quarter watt resistors now. A 1K, 2-Watt resistor will be installed later.

Desig	Value	Color code	Done <input checked="" type="checkbox"/> Left	Done <input checked="" type="checkbox"/> Right
R19	100K	Brown, Black, Black, Orange, Brown	<input type="checkbox"/>	<input type="checkbox"/>
R24	100K	Brown, Black, Black, Orange, Brown	<input type="checkbox"/>	<input type="checkbox"/>
R28	100K	Brown, Black, Black, Orange, Brown	<input type="checkbox"/>	<input type="checkbox"/>
R29	100K	Brown, Black, Black, Orange, Brown	<input type="checkbox"/>	<input type="checkbox"/>
R1	10K0	Brown, Black, Black, Red, Brown	<input type="checkbox"/>	<input type="checkbox"/>
R18	10K0	Brown, Black, Black, Red, Brown	<input type="checkbox"/>	<input type="checkbox"/>
R35	10K0	Brown, Black, Black, Red, Brown	<input type="checkbox"/>	<input type="checkbox"/>
R6	10K0	Brown, Black, Black, Red, Brown	<input type="checkbox"/>	<input type="checkbox"/>
R12	10R0	Brown, Black, Black, Gold, Brown	<input type="checkbox"/>	<input type="checkbox"/>
R13	158	Brown, Green, Gray, Black, Brown	<input type="checkbox"/>	<input type="checkbox"/>
R27	1K00	Brown, Black, Black, Brown, Brown	<input type="checkbox"/>	<input type="checkbox"/>
R38	1K00	Brown, Black, Black, Brown, Brown	<input type="checkbox"/>	<input type="checkbox"/>
R39	1K00	Brown, Black, Black, Brown, Brown	<input type="checkbox"/>	<input type="checkbox"/>
R8	1K00	Brown, Black, Black, Brown, Brown	<input type="checkbox"/>	<input type="checkbox"/>
R9	1K00	Brown, Black, Black, Brown, Brown	<input type="checkbox"/>	<input type="checkbox"/>
R30	1Meg	Brown, Black, Black, Yellow, Brown	<input type="checkbox"/>	<input type="checkbox"/>

¹ See "Appendix 3 - Resistor Color Code" on page 24 to see how to read resistor color codes.

Desig	Value	Color code	Done <input checked="" type="checkbox"/> Left	Done <input checked="" type="checkbox"/> Right
R31	1Meg	Brown, Black, Black, Yellow, Brown	<input type="checkbox"/>	<input type="checkbox"/>
R14	20K0	Red, Black, Black, Red, Brown	<input type="checkbox"/>	<input type="checkbox"/>
R15	20K0	Red, Black, Black, Red, Brown	<input type="checkbox"/>	<input type="checkbox"/>
R20	20K0	Red, Black, Black, Red, Brown	<input type="checkbox"/>	<input type="checkbox"/>
R26	20K0	Red, Black, Black, Red, Brown	<input type="checkbox"/>	<input type="checkbox"/>
R34	24K9	Red, Yellow, White, Red, Brown	<input type="checkbox"/>	<input type="checkbox"/>
R11	28K0	Red, Gray, Black, Red, Brown	<input type="checkbox"/>	<input type="checkbox"/>
R23	294K	Red, White, Yellow, Orange, Brown	<input type="checkbox"/>	<input type="checkbox"/>
R32	36K0	Orange, Blue, Black, Red, Brown	<input type="checkbox"/>	<input type="checkbox"/>
R22	392	Orange, White, Red, Black, Brown	<input type="checkbox"/>	<input type="checkbox"/>
R2	3K01	Orange, Black, Brown, Brown, Brown	<input type="checkbox"/>	<input type="checkbox"/>
R5	4.7 Meg	Yellow, Violet, Black, Yellow, Brown	<input type="checkbox"/>	<input type="checkbox"/>
R16	4640	Yellow, Blue, Yellow, Brown, Brown	<input type="checkbox"/>	<input type="checkbox"/>
R21	470K	Yellow, Violet, Black, Orange, Brown	<input type="checkbox"/>	<input type="checkbox"/>
R33	499	Yellow, White, White, Black, Brown	<input type="checkbox"/>	<input type="checkbox"/>
R7	49K9	Yellow, White, White, Red, Brown	<input type="checkbox"/>	<input type="checkbox"/>
R10	56K2	Green, Blue, Red, Red, Brown	<input type="checkbox"/>	<input type="checkbox"/>
R37	5900	Green, White, Black, Brown, Brown	<input type="checkbox"/>	<input type="checkbox"/>
R25	59K0	Green, White, Black, Red, Brown	<input type="checkbox"/>	<input type="checkbox"/>
R3	66K5	Blue, Blue, Green, Red, Brown	<input type="checkbox"/>	<input type="checkbox"/>
R17	68	Blue, Gray, Black, Gold, Brown	<input type="checkbox"/>	<input type="checkbox"/>
R36	73K2	Violet, Orange, Red, Red, Brown	<input type="checkbox"/>	<input type="checkbox"/>

Now install the diodes. Be careful, as diodes are polarized. ***The direction of insertion matters!*** Make sure to line up the banded end of the diode with the banded end of the silk-screen. Note that the LED will be installed at a later step.

Desig	Value, type, physical description	Done <input checked="" type="checkbox"/> Left	Done <input checked="" type="checkbox"/> Right
D1	10 Volt Zener, glass body, "B10"	<input type="checkbox"/>	<input type="checkbox"/>
D2	75-volt switching diode 1N4148, glass body "48"	<input type="checkbox"/>	<input type="checkbox"/>
D4	75-volt switching diode 1N4148, glass body "48"	<input type="checkbox"/>	<input type="checkbox"/>
D3	400 Volt rectifier 1N4004, black body, "4004"	<input type="checkbox"/>	<input type="checkbox"/>

Now you'll install the small, axial leaded non-polarized capacitors. They look like the resistors, in that the leads exit from both ends, hence the "axial" designation. The body is small and brown in color. These capacitors can be installed without regard to orientation.

Desig	Value, type	Marking	Done <input checked="" type="checkbox"/> Left	Done <input checked="" type="checkbox"/> Right
C2	100pF, COG	101, there will be other numbers and letters, but find the 101	<input type="checkbox"/>	<input type="checkbox"/>
C37	100pF, COG	101, there will be other numbers and letters, but find the 101	<input type="checkbox"/>	<input type="checkbox"/>
C10	270p, COG	271, there will be other numbers and letters, but find the 271	<input type="checkbox"/>	<input type="checkbox"/>
C13	270p, COG	271, there will be other numbers and letters, but find the 271	<input type="checkbox"/>	<input type="checkbox"/>

We'll go back now and install the 1 Watt resistor.

Desig	Value	Marking	Done <input checked="" type="checkbox"/>	Done <input checked="" type="checkbox"/>
R4	1K, 2Watt, 5%	1K	<input type="checkbox"/>	<input type="checkbox"/>

Now install the film capacitors. They are radial capacitors, shaped like a box, with both leads exiting from the same side.

Desig	Value	Marking	Done <input checked="" type="checkbox"/>	Done <input checked="" type="checkbox"/>
C11	0.1u, film	μ 1J100	<input type="checkbox"/>	<input type="checkbox"/>
C12	0.1u, film	μ 1J100	<input type="checkbox"/>	<input type="checkbox"/>
C19	0.1u, film	μ 1J100	<input type="checkbox"/>	<input type="checkbox"/>
C24	0.1u, film	μ 1J100	<input type="checkbox"/>	<input type="checkbox"/>
C21	0.22u, film	μ 22J100	<input type="checkbox"/>	<input type="checkbox"/>
C7	0.27u film	270nJ	<input type="checkbox"/>	<input type="checkbox"/>
C8	0.27u film	270nJ	<input type="checkbox"/>	<input type="checkbox"/>
C16	68n, film, 5%	68nJ100	<input type="checkbox"/>	<input type="checkbox"/>
C27	10n, 1% film	10nF (relatively large green box)	<input type="checkbox"/>	<input type="checkbox"/>
C18	15n, film	15nJ100	<input type="checkbox"/>	<input type="checkbox"/>
C28	2.2n, film, 2.5%	2200/63	<input type="checkbox"/>	<input type="checkbox"/>
C26	47n, 1% film	47nF (note that C26 and C14 have different tolerances and different sizes!)	<input type="checkbox"/>	<input type="checkbox"/>
C14	47n, film, 5%	47nJ100	<input type="checkbox"/>	<input type="checkbox"/>
C22	1u@63V, film	1J63	<input type="checkbox"/>	<input type="checkbox"/>
C3	4u7@63V, film cap	4,7uF	<input type="checkbox"/>	<input type="checkbox"/>

Note: there is a location for C5 in the RevC Ver1 board, but it is not used.

Now install the relay, K1. Here are a few hints to make the installation trouble-free:

1. Be careful that all 8 pins are not bent-over before installation.
2. Insert the relay, and solder just two corner pins.
3. Examine the relay to assure that it sits flat on the board. If not, this is an easy time to melt the solder on the pins to get the relay to sit flat.
4. Solder the remaining pins once you're sure the relay is sitting flat.

Desig	Value	Done <input checked="" type="checkbox"/>	Done <input checked="" type="checkbox"/>
K1	DPDT, 24-volt coil	<input type="checkbox"/>	<input type="checkbox"/>

Install the electrolytic capacitors. **The polarity is important. Be sure to look at the polarity as marked on the silk screen, and make it agree with the capacitor markings.** The silk screen marks the positive side of the capacitor. The capacitors mark the **negative** side of the capacitor! Make sure that the negative side of the capacitor sits in the hole away from the positive marking on the PCB.

Note: If the capacitor leads are uncut, then the longer lead is the positive lead.

Desig	Value	Marking	Done <input checked="" type="checkbox"/> Left	Done <input checked="" type="checkbox"/> Right
C1	47u@50V, electrolytic	See the value column	<input type="checkbox"/>	<input type="checkbox"/>
C36	47u@50V electrolytic	See the value column	<input type="checkbox"/>	<input type="checkbox"/>
C20	47u@50V, electrolytic	See the value column	<input type="checkbox"/>	<input type="checkbox"/>
C23	47u@50V, electrolytic	See the value column	<input type="checkbox"/>	<input type="checkbox"/>
C6	47u@50V, electrolytic	See the value column	<input type="checkbox"/>	<input type="checkbox"/>
C4	47u@50V, electrolytic	See the value column	<input type="checkbox"/>	<input type="checkbox"/>
C29	330μ@25V, electrolytic	See the value column	<input type="checkbox"/>	<input type="checkbox"/>
C31	330μ@25V, electrolytic	See the value column	<input type="checkbox"/>	<input type="checkbox"/>

Install the transistors. Match the shape of the transistor body to the shape of the silk-screen. Leave about 0.3” of space between the top of the transistor package and the PCB.



Figure 6-Proper height for transistor installation

Don't get too much heat onto the transistors.

Desig	Value	Marking	Done <input checked="" type="checkbox"/> Left	Done <input checked="" type="checkbox"/> Right
Q1	2N5088, high gain low noise NPN	2N5088	<input type="checkbox"/>	<input type="checkbox"/>
Q4	2N5088, high gain low noise NPN	2N5088	<input type="checkbox"/>	<input type="checkbox"/>
Q2	2N3904, 40V NPN	2N3904	<input type="checkbox"/>	<input type="checkbox"/>
Q3	2N3904, 40V NPN	2N3904	<input type="checkbox"/>	<input type="checkbox"/>
Q5	2N3904, 40V NPN	2N3904	<input type="checkbox"/>	<input type="checkbox"/>
Q6	2N3904, 40V NPN	2N3904	<input type="checkbox"/>	<input type="checkbox"/>
Q7	2N3904, 40V NPN	2N3904	<input type="checkbox"/>	<input type="checkbox"/>
Q8	2N3904, 40V NPN	2N3904	<input type="checkbox"/>	<input type="checkbox"/>

Q9	2N3904, 40V NPN	2N3904	<input type="checkbox"/>	<input type="checkbox"/>
Q10	2N3904, 40V NPN	2N3904	<input type="checkbox"/>	<input type="checkbox"/>
Q11	2N3904, 40V NPN	2N3904	<input type="checkbox"/>	<input type="checkbox"/>
Q12	2N3904, 40V NPN	2N3904	<input type="checkbox"/>	<input type="checkbox"/>
Q13	2N3904, 40V NPN	2N3904	<input type="checkbox"/>	<input type="checkbox"/>
T1	ZVN2110A, 100 Volt MOSFET, or ZVN3310	ZVN2110A or ZVN3310	<input type="checkbox"/>	<input type="checkbox"/>

Install the LED. LED's are polarity sensitive. Make sure to install the LED so that the flat on the package (the cathode) matches the flat on the silk screen. Sometimes it's tough to find the flat. If you haven't cut the leads of the LED, **the longer LED lead goes into the LED1 hole closest to the relay.**



Figure 7-Closeup of LED, note anode is longer

Desig	Value	Done <input checked="" type="checkbox"/> Left	Done <input checked="" type="checkbox"/> Right
LED1	T1 LED green	<input type="checkbox"/>	<input type="checkbox"/>

Install the heatsink on Q7. Clip the heatsink to Q7 by sliding it down over the body of Q7.

Prepare and Add Shielded Cables to the Inputs

For lowest hum, you must use shielded cable between the PHONO LOW RCA Jacks and the inputs on the PCB. Prepare two lengths of shielded cable:

1. A 9" length for the right² channel, using the red conductor and the drain wire.
2. A 6" length for the left channel, using the black conductor and the drain wire.

Details on the preparation of the shielded cables can be found in Appendix 2 - Preparing a Shielded Cable End. Prepare both ends of both pieces of shielded cable now, as it will make it much easier to later complete installation of the input wiring.

² Note that the right channel PCB mounts toward the front of the chassis, and so the length of shielded cable for the phono inputs must be a bit longer.



Figure 8-Shielded cable installation (right channel shown here)

Connect the wires as follows on the Right Channel PCB. The right channel PCB gets the longer piece of shielded cable:

1. Right channel signal wire (red) to eyelet 1. Insert from the component side and solder on the solder side.
2. Right channel drain wire (bare wire covered with added gray outer jacket) to eyelet 2. Insert from the component side and solder on the solder side.

Connect the wires as follows on the Left Channel PCB. The left channel PCB gets the shorter piece of shielded cable:

1. Left channel signal wire (black) to eyelet 1. Insert from the component side and solder on the solder side.
2. Left channel drain wire (bare wire covered with added gray outer jacket) to eyelet. Insert from the component side and solder on the solder side.

Double check that you have not reversed the ground and signal wires.

Installing the Assembled Circuit Boards

Preparing to Install the Assembled PAT4PPR Circuit Board

1. Disconnect the PAT-4 from your music system.
2. Unplug the power cord and allow the preamp to sit for one minute before moving on.

Caution: Be sure that the preamp power is unplugged! 120 VAC can be lethal! 240 VAC can be lethal!

3. Remove the 4 screws that hold the cover in place, 2 on the left side and 2 on the right side. Some PAT-4 preamps may have a 5th screw in the back cover.
4. Lift the cover straight up and set it aside in a safe place.

Prerequisites

The PAT4PWR supply must be installed along with the PAT4RENEW upgrade. The reason is that the PAT4PWR supply generates a -17.5 Volt supply that is used to bias the stages in the PAT4RENEW.

If your PAT4 doesn't have the Updatemydynaco PAT4PWR supply:

- Download the PAT4PWR (Electronically Regulated Power Supply Manual).
- Build and install the PAT4PWR according to the directions in that manual, then apply the modifications as listed in the section below. It is probably reasonable to connect the PAT4PWR to the transformer, but not to bother with the DC power connections to the circuit boards, as they will all be changed when you install the new preamp circuit boards.

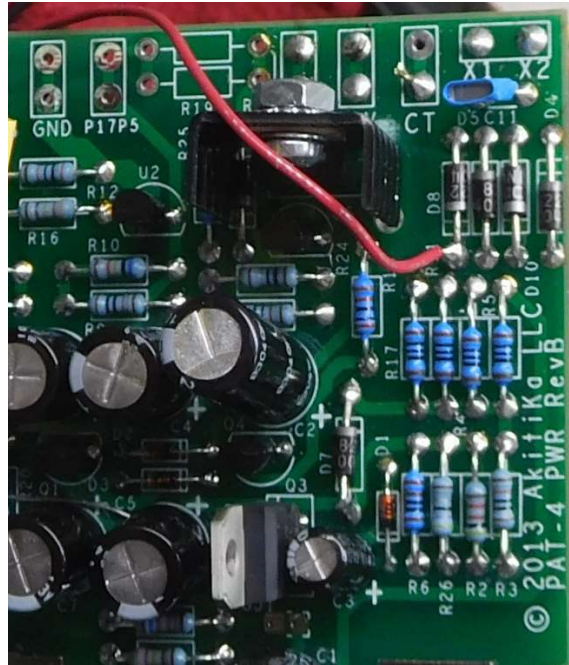

Figure 9-Adding the power good wire to D8's cathode

PAT-4 Power Modifications, PAT4PWR Rev B

The modifications listed here apply to the Rev B version of the PAT-4 Power:

Apply the following changes to an assembled and tested PAT4 power. Alternatively, you can do these changes when you build the new PAT-4 Power supply.

1. De-solder or clip out both R19 and R15. That disables the +17.5-volt power supply and saves current capability for the 38 Volt output.
2. Change R13 from 23K2 to 20K0 resistor. The 20K0 resistor is supplied as part of this kit. That change will drop the regulated voltage from 38 Volts to 35 Volts.
3. Cut a 10" length of red 26 AWG solid wire. Remove 3/8" of insulation from only one end. Solder the stripped end to the CATHODE (banded end) of D8.
4. You can wrap it around the lead on the component side and solder it. This connection forms a "power good" signal that is used by the muting and timing circuits. See Figure 9.

PAT-4 Power Modifications, PAT4PWR Rev C

The modifications listed here apply to the Rev C version of the PAT-4 Power, which began shipping August 1, 2020:

Apply the following changes to an assembled and tested PAT4 power. Alternatively, you can do these changes when you build the new PAT-4 Power supply.

1. De-solder or clip out both R20 and R21. That disables the +17.5-volt power supply and saves current capability for the 38 Volt output.
2. Change R17 from 23K2 to 20K0 resistor. The 20K0 resistor is supplied as part of this kit. That change will drop the regulated voltage from 38 Volts to 35 Volts.
3. Cut a 10" length of red 26 AWG solid wire. Remove 3/8" of insulation from only one end. Insert the stripped end into the solder side of the power supply board, either VRAW1 or VRAW2. Solder the wire on the component side of the board. This connection forms a "power good" signal that is used by the muting and timing circuits.

Removing the original boards

For both the FRONT and BACK preamp PCB's, you will **label and desolder the wires in the numbered eyelets**. Use the supplied numbered labels...It makes it much easier to do the reassembly correctly.

- The F labels are used with the FRONT (right channel) PCB.
- The B labels are used with the BACK (left channel) PCB.

Eyelet number	FRONT (✓)	BACK (✓)	Description of the original function
1	<input type="checkbox"/>	<input type="checkbox"/>	Phono preamp input
2	<input type="checkbox"/>	<input type="checkbox"/>	Phono preamp signal ground
3	<input type="checkbox"/>	<input type="checkbox"/>	Phono preamp power ground
4	<input type="checkbox"/>	<input type="checkbox"/>	Phono preamp power supply (+17.5 volts originally)
5	<input type="checkbox"/>	<input type="checkbox"/>	Phono preamp output
6	<input type="checkbox"/>	<input type="checkbox"/>	Phono feedback
7	<input type="checkbox"/>	<input type="checkbox"/>	Tape head feedback
8	<input type="checkbox"/>	<input type="checkbox"/>	Special Feedback
9	<input type="checkbox"/>	<input type="checkbox"/>	Line stage input
10	<input type="checkbox"/>	<input type="checkbox"/>	Line stage input ground
11	<input type="checkbox"/>	<input type="checkbox"/>	Line stage power ground
12	<input type="checkbox"/>	<input type="checkbox"/>	Line stage power supply (+38 volts originally)
13	<input type="checkbox"/>	<input type="checkbox"/>	Bass control
14	<input type="checkbox"/>	<input type="checkbox"/>	Bass control
15	<input type="checkbox"/>	<input type="checkbox"/>	Bass control
16	<input type="checkbox"/>	<input type="checkbox"/>	Treble control
17	<input type="checkbox"/>	<input type="checkbox"/>	Treble control
18	<input type="checkbox"/>	<input type="checkbox"/>	Treble control
19	<input type="checkbox"/>	<input type="checkbox"/>	Preamp output

Please note that some of wires will be rearranged and/or repurposed when the new boards are installed.

The boards should now be quite easy to remove.

1. Remove the 6-32 screw and nut in the center of each bracket, then lift the bracket and PCB assembly out of the PAT-4.

2. Remove the four 4-40 screws, nuts, and lockwashers from the FRONT PCB. Save the screws for later re-use.
3. Remove the four 4-40 screws, nuts, and lockwashers from the BACK PCB. Save the screws for later re-use.
4. Save the U-shaped brackets for later re-use.
5. Take a minute to fish the old #4 lockwashers out of the chassis so they don't end up in a bad place at a bad time. These lockwashers will not be re-used.

Modify the PAT-4 Wiring for PHONO plus 5 High-Level inputs

Refer to Figure 10 to locate the wires to be cut or altered for the following tasks. Match the Callout numbers in the task list to the callout numbers on Figure 10.

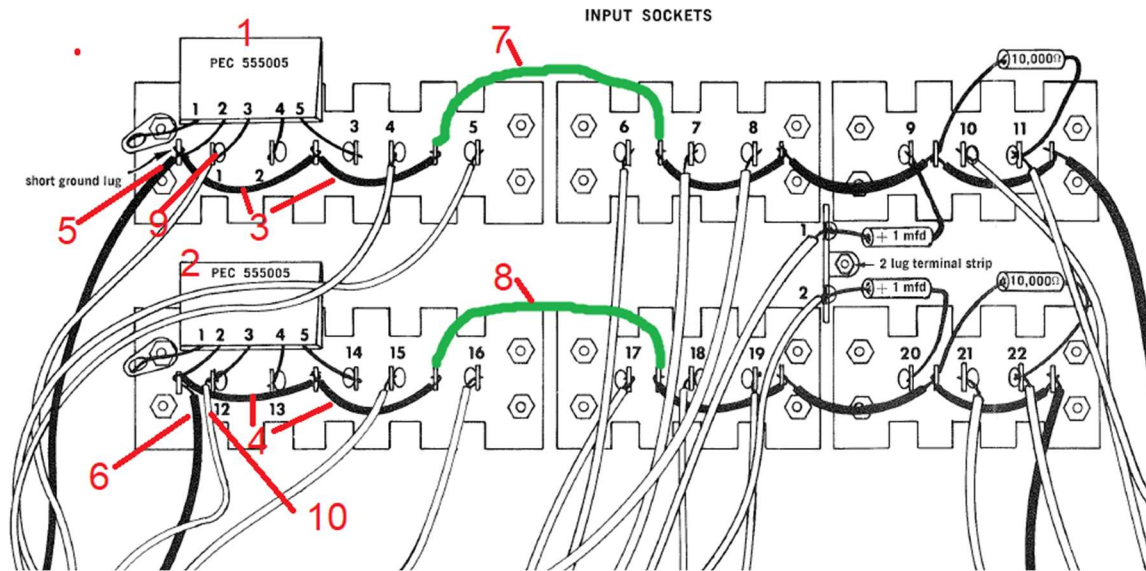

Figure 10-Back Panel wire cuts and ground additions

Note: wires are shown in green to make them easy to see, but you will use black wire to callouts 7 and 8

Callout	Task – Remove PEC555005's, cut and add some wires. <u>These cuts only occur on the back panel of the PAT-4 in the RCA jack field.</u>	Done(✓)
1	Remove the LEFT channel PEC555005 network. This network is connected to the top row of RCA jacks and a chassis lug. Clip the 5 leads near the RCA jack or the chassis lugs. The PEC555005 will not be re-used.	<input type="checkbox"/>
2	Remove the RIGHT channel PEC555005 network. This network is connected to the bottom row of RCA jacks and a chassis lug. Clip the 5 leads near the RCA jack or the chassis lugs. The PEC555005 will not be re-used.	<input type="checkbox"/>
3	Cut both ends of both wires in callout 3 close to the ground terminals.	<input type="checkbox"/>
4	Cut both ends of both wires in callout 4 close to the ground terminals.	<input type="checkbox"/>

5	Cut the end of the wire in callout 5 where it attaches to the ground lug of the RCA jacks. Label it with the 3B(new) label.	<input type="checkbox"/>
6	Cut the end of the wire in callout 6 where it attaches to the ground lug of the RCA jacks. Label it with the 3F(new) label.	<input type="checkbox"/>
7	Use the supplied black 22 AWG solid wire to make the ground connection shown in green in callout 7.	<input type="checkbox"/>
8	Use the supplied black 22 AWG solid wire to make the ground connection shown in green in callout 8.	<input type="checkbox"/>
9	Cut the wire in callout 9 close to where it meets the hot connection of the LEFT PHONO LOW. Label it with the 5B(new) label.	<input type="checkbox"/>
10	Cut the wire in callout 10 close to where it meets the hot connection of the RIGHT PHONO LOW. Label it with the 5F(new) label.	<input type="checkbox"/>

Hint: if you're having trouble getting to the back-panel jacks to make these changes, you can remove 4 screws, 2 screws on each side of the back panel that hold it to the bottom of the chassis.

Ground Philosophy: What are we doing with the rearrangement of the grounds? We are separating the phono inputs from the all the rest of the grounds. This prevents a ground loop, which keeps the phono section as free from hum as possible. You'll note that the grounds of the PHONO LOW inputs don't touch the chassis.

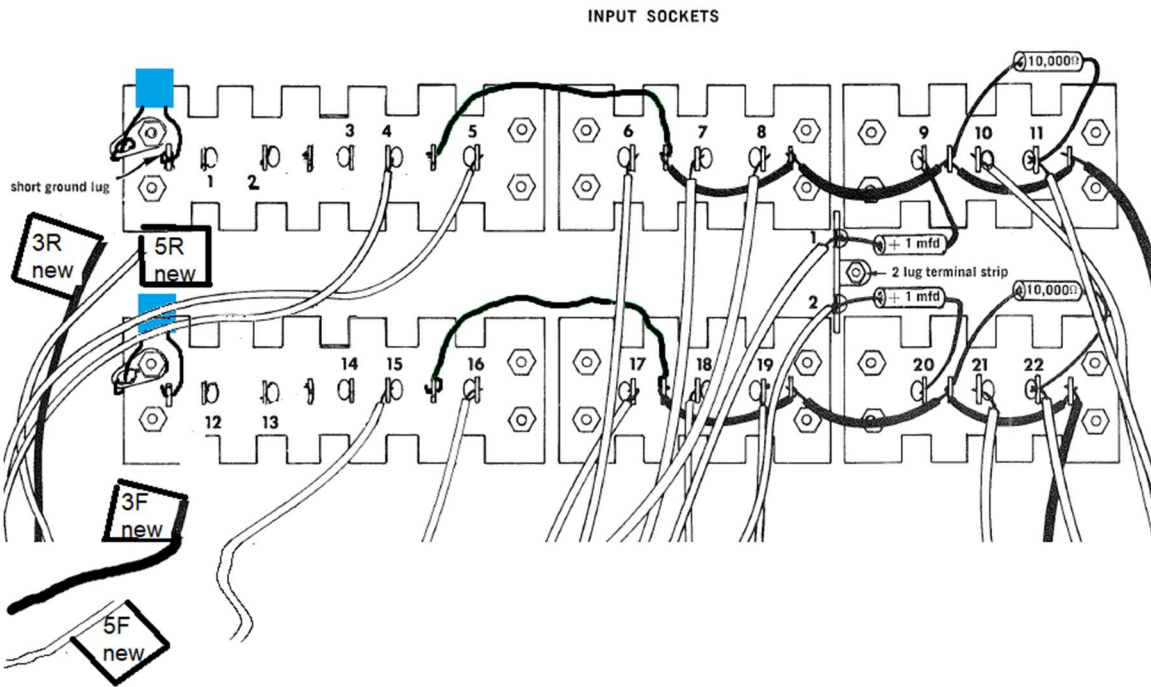

Figure 11-back panel after previous set of tasks and addition of 0.01 uF caps

Callout	Callouts for this chart are in Figure 11	Done(✓)
---------	--	---------

	Add a 0.01 μ F 100V capacitor (blue box cap) from the LEFT phono LOW RCA ground to the nearby chassis ground lug.	
	Add a 0.01 μ F 100V capacitor (blue box cap) from the RIGHT phono LOW RCA ground to the nearby chassis ground lug.	

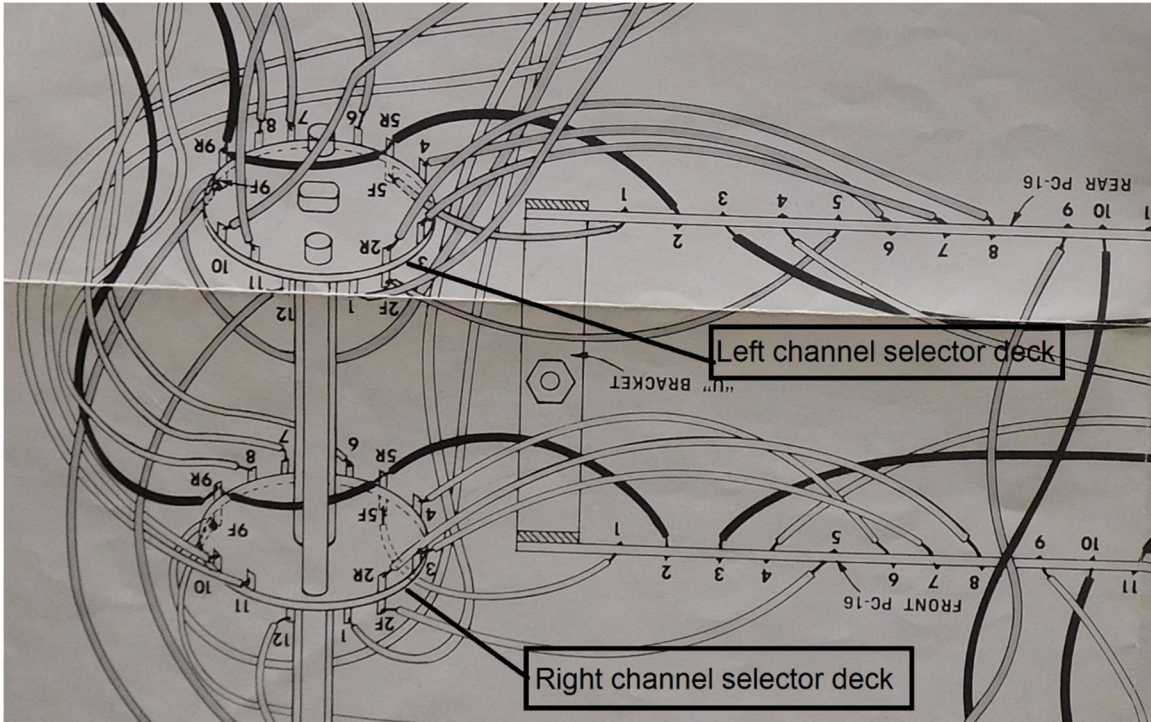

Figure 12-Original switch wiring

Task - Selector Switch Wiring Changes		Done
Refer to Figure 12 to identify switch terminals		✓
<i>The purpose of the next steps is to end up with the right channel selector deck terminal 2F tied to switch terminal 5F.</i>		<input type="checkbox"/>
Identify the wire that connects to terminal 5F of the front deck of the selector switch. <ul style="list-style-type: none"> If you started with a stock PAT4, this wire would have a 1F label attached. 	<input type="checkbox"/>	
Identify the wire that connects to terminal 2F of the front deck of the selector switch. <ul style="list-style-type: none"> If you started with a stock PAT4, this wire would have a 5F label attached. 	<input type="checkbox"/>	
Note where the 5F-labeled wire connects to the 2F terminal of the switch. Desolder the 2F terminal side of the 5F-labeled wire and discard the 5F labeled wire. Connect the free end of the 1F labeled wire to the 2F terminal of the front deck of the selector switch.	<input type="checkbox"/>	

<i>The purpose of the next steps is to end up with the left channel selector deck terminal 2F tied to switch terminal 5F.</i>	<input type="checkbox"/>
Identify the wire that connects to terminal 5F of the rear deck of the selector switch. <ul style="list-style-type: none"> If you started with a stock PAT4, this wire would have a 1B label attached. 	<input type="checkbox"/>
Identify the wire that connects to terminal 2F of the rear deck of the selector switch. <ul style="list-style-type: none"> If you started with a stock PAT4, this wire would have a 5B label attached 	<input type="checkbox"/>
Note where the 5B-labeled wire connects to the 2F terminal of the rear-deck of the selector switch. Desolder the 2F terminal side of the 5B-labeled wire and discard the 5B labeled wire. Connect the free end of the 1B labeled wire to the 2F terminal of the rear deck of the selector switch.	<input type="checkbox"/>

Clear away a few old wires

Clear away the following wires by desoldering them from the front deck of the selector switch:

Task	Done
	✓
Desolder wire labeled 6F from the selector switch and discard the wire.	<input type="checkbox"/>
Desolder wire labeled 7F from the selector switch and discard the wire.	<input type="checkbox"/>
Desolder wire labeled 8F from the selector switch and discard the wire.	<input type="checkbox"/>

Clear away the following wires by desoldering them from the rear deck of the selector switch:

Task	Done
	✓
Desolder wire labeled 6B from the selector switch and discard the wire.	<input type="checkbox"/>
Desolder wire labeled 7B from the selector switch and discard the wire.	<input type="checkbox"/>
Desolder wire labeled 8B from the selector switch and discard the wire.	<input type="checkbox"/>

Install the Boards onto the Mounting Brackets

As you mount the boards, you will re-use the original 4-40 slotted-head screws. However, you will use the supplied 4-40 keps nuts with the built-in lock-washer.



Figure 13-Re-use the original 4-40 screws to re-attach mounting brackets to the PCBs

Connect the PHONO LOW RCA Jacks

Set the assembly of the boards on the mounting brackets into the preamp. Make sure that:

1. The component side of the assembly faces the back of the preamp.
2. The shielded cables you installed in a previous step are on the same side as the PHONO LOW connectors.

Now wire up the shielded cables to the PHONO LOW RCA jacks.

1. Right channel signal conductor (red) to center of right channel PHONO LOW RCA jack.
2. Right channel ground conductor (drain wire covered with a bit of reserved gray jacket insulation) to the ground lug of the right channel PHONO LOW RCA jack.
3. Left channel signal conductor (black) to center of left channel PHONO LOW RCA jack.
4. Left channel ground conductor (drain wire covered with a bit of reserved gray jacket insulation) to the ground lug of the left channel PHONO LOW RCA jack.

Installing Power Wires

You'll now wire up the new PCBs to the power supply. For the neatest wiring, you'll probably want to remove the wires that were previously connected to the GND and 38V eyelets on the power supply.

	Done ✓
Cut two 7" lengths of the supplied red/black twisted 22 AWG wire. Strip all the ends by removing 3/8" of insulation from each of the eight ends.	<input type="checkbox"/>
For the RIGHT channel PCB, closest to the front of the preamp (the one with the longer shielded cable)), install the wires from the component side and solder them on the solder side: <ul style="list-style-type: none"> • RED wire into Eyelet 12 • BLACK wire into Eyelet 11 	<input type="checkbox"/>

<p>Run the free ends of this RED/BLACK wire pair to the power supply board. Install the wires from the solder side and solder them on the component side:</p> <ul style="list-style-type: none"> • RED wire into the lower 38V hole • BLACK wire into the adjacent GND hole. 	<input type="checkbox"/>
<p>For the LEFT channel PCB (that's the one closest to the back of the preamp, the one with the shorter shielded cable), install the wires from the solder side and solder them on the component side:</p> <ul style="list-style-type: none"> • RED wire into Eyelet 12 • BLACK wire into Eyelet 11 	<input type="checkbox"/>
<p>Run the free ends of this RED/BLACK wire pair to the power supply board. Install the wires from the solder side and solder them on the component side:</p> <ul style="list-style-type: none"> • RED wire into the upper 38V hole • BLACK wire into the adjacent GND hole. 	<input type="checkbox"/>
<p>If your PAT4PWR is REVB: Strip the free end of the red 26 AWG power wire that connects to D8's cathode on the PAT4PWR. Insert it into the component side of the RIGHT channel PCB EYELET 7, but don't solder it yet.</p>	
<p>If your PAT4PWR is REVC: Run a piece of the supplied 26 AWG wire from one of the VRAW terminals on the power supply to EYELET 7 on the front PCB.</p> <ul style="list-style-type: none"> • At the VRAW end, insert it into the component side and solder it on the solder side. • Insert the other end of the wire into the component side of EYELET 7 on the front PCB. Don't solder it yet, as another wire will be added to this one in the next step. 	
<p>Cut a 3" length of 26 AWG red solid wire (supplied) and remove 3/8" of insulation from both ends.</p> <ul style="list-style-type: none"> • Install one end into the solder side of LEFT (back) channel EYELET 7, and solder the wire in that eyelet on the component side of the board. • Install the other end of this wire from the component side of the front (RIGHT channel) EYELET 7, and solder both wires on the solder side. 	
<p>Cut two 7" lengths of the supplied 22 AWG solid blue wire. Remove 3/8" of insulation from all 4 ends.</p>	
<p>Install one end of one blue wire into the lower N17P5 eyelet of the power supply. Insert it from the solder side and solder it on the component side.</p>	
<p>Install the other end of that blue wire into the RIGHT channel (Front) PCB, inserting it into the component side EYELET 8 and soldering it on the solder side.</p>	
<p>Install one end of the other blue wire into the upper N17P5 eyelet of the power supply. Insert it from the solder side and solder it on the component side.</p>	

Install the free end of that blue wire into the LEFT channel (BACK) PCB, inserting it into the solder side EYELET 8 and soldering it on the component side.	
---	--

Reconnecting the Rest of the labeled wires

You'll now re-connect all of the labeled wires that were previously removed from the original PC boards. We'll do the front and back PCB's separately.

Reconnect the wires for the FRONT PCB.

Eyelet #	Action (or comment)	Done ✓
1	Should already be connected to center conductor of shielded cable.	<input type="checkbox"/>
2	Should already be connected to drain wire of shielded cable.	<input type="checkbox"/>
3	Ground from selector switch, labeled 3F(new).	<input type="checkbox"/>
4	Not used	<input type="checkbox"/>
5	Solder to 5F(new) wire, which was previously connected to the right channel PHONO LOW RCA jack.	<input type="checkbox"/>
6	Not used	<input type="checkbox"/>
7	Was connected to RED 26 AWG wire as part of this re-build.	<input type="checkbox"/>
8	Was connected to the BLUE 22 AWG wire that runs to NEG17P5 on the power supply as part of this re-build.	<input type="checkbox"/>
9	Reinstall and solder wire labeled 9F. (high level stage input)	<input type="checkbox"/>
10	Reinstall and solder wire labeled 10F.(high level stage ground)	<input type="checkbox"/>
11	Previously connected to ground from power supply.	<input type="checkbox"/>
12	Previously connected to 38 Volt eyelet from power supply.	<input type="checkbox"/>
13	Reinstall and solder wire labeled 13F	<input type="checkbox"/>
14	Reinstall and solder wire labeled 14F	<input type="checkbox"/>
15	Reinstall and solder wire labeled 15F	<input type="checkbox"/>
16	Reinstall and solder wire labeled 16F	<input type="checkbox"/>
17	Reinstall and solder wire labeled 17F	<input type="checkbox"/>
18	Reinstall and solder wire labeled 18F	<input type="checkbox"/>
19	Reinstall and solder wire labeled 19F	<input type="checkbox"/>

Reconnect the wires for the BACK PCB.

Eyelet #	Action (or comment)	Done ✓
1	Should already be connected to center conductor of shielded cable.	<input type="checkbox"/>
2	Should already be connected to drain wire of shielded cable.	<input type="checkbox"/>
3	Ground from selector switch, labeled 3B(new).	<input type="checkbox"/>
4	Not used	<input type="checkbox"/>
5	Solder to 5B(new) wire, which was previously connected to the left channel PHONO LOW RCA jack.	<input type="checkbox"/>
6	Not used	<input type="checkbox"/>

7	This was already connected to a RED 26 AWG wire as part of this rebuild.	<input type="checkbox"/>
8	Was connected to the BLUE 22 AWG wire that runs to NEG17P5 on the power supply as part of this rebuild.	<input type="checkbox"/>
9	Reinstall and solder wire labeled 9B.	<input type="checkbox"/>
10	Reinstall and solder wire labeled 10B.	<input type="checkbox"/>
11	Previously connected to ground from power supply.	<input type="checkbox"/>
12	Previously connected to 38 Volt eyelet from power supply.	<input type="checkbox"/>
13	Reinstall and solder wire labeled 13B	<input type="checkbox"/>
14	Reinstall and solder wire labeled 14B	<input type="checkbox"/>
15	Reinstall and solder wire labeled 15B	<input type="checkbox"/>
16	Reinstall and solder wire labeled 16B	<input type="checkbox"/>
17	Reinstall and solder wire labeled 17B	<input type="checkbox"/>
18	Reinstall and solder wire labeled 18B	<input type="checkbox"/>
19	Reinstall and solder wire labeled 19B	<input type="checkbox"/>

If you have already installed the upgraded PAT4 Selector Kit

This section covers exceptions that apply only if you have the PAT4 Selector Kit. In that case:

1. The I1 Eyelet in the left channel of the input selector board connects to eyelet 5 of the REAR (left channel) PAT4 Renewal board.
2. The I1 Eyelet in the right channel of the input selector board connects to eyelet 5 of the FRONT (right channel) PAT4 Renewal board.
3. No wire connects to pin 3 of either PAT4 Renewal board.

Inspection and Preliminary Reassembly

Inspect your work for good solder joints and freedom from solder bridges. Touch up any questionable connections now.

Final Sanity Checks

Here are a few last tests before you reconnect your PAT-4 to your music system. With the top still off, plug in the AC mains. Turn on the power switch. Set your meter to DC volts. Connect one lead of the meter to ground.

<i>Be careful! These steps are performed with the power connected and turned on!</i>	Done ✓	Done ✓
The voltage on the NEG17P5 terminal of the new phono preamp should measure between -17 and -18 Volts DC (with respect to ground).	<input type="checkbox"/>	<input type="checkbox"/>
The voltage on eyelet 12 of both preamp PCB's should measure between 33 and 37 volts DC (with respect to ground).	<input type="checkbox"/>	<input type="checkbox"/>

Prepare to Reconnect your PAT-4 to your Music System

- Turn off the power.
- Remove the AC plug from the wall socket.

- Replace the cover.
- Reinstall the four (or five) screws that hold the cover in place.
- Reinstall the PAT-4 to your music system.
- Notes:
 - Use the PHONO LOW input for your turntable. The other two PHONO inputs, PHONO HIGH and PHONO CER are disconnected.
 - Given the 5 high-level and one phono wiring, then:
 - The TAPE HEAD input is a high-level input
 - The SPECIAL input is a high-level input

Record Playing Reminders

If it has been a while since you've played records here are a few hints that you may find useful.

- The ground wire between the turntable and the ground screw on the back-panel of the PAT-4 preamp must be connected to minimize the hum. Usually, that wire runs loosely along with the RCA cords.
- Check your tracking force and anti-skating force. Re-balance your tone arm if it has been a while.
- Make sure that the grounding crown of the RCA plugs fit snugly around the grounds of on the preamp inputs. A good connection is important for low noise performance.
- Watch for acoustic feedback that can arise if the speakers are too close to the turntable. Increasing the space between the speakers and the turntable will help.
- The signal to noise ratio (SNR) of a record isn't what you're used to with digital, it's less. Still, the music on the records mostly masks the noise, except in soft portions, or if the record is worn or dirty.
- Is one channel out? Swap phono outputs and preamp inputs to get to the bottom of the problem. This will let you figure out if it's a turntable/cartridge problem or a preamp problem.
- A frequent source of "one channel out" problems in the turntable/cartridge system comes from bad connections between the wires in the head-shell and the phono cartridge. The push-on connectors become flakey. If this is the issue, you can often renew the connection by carefully rotating the push-on connector on the cartridge's input pin:
 - Be careful not to bump the stylus or catilever.
 - Hold the cartridge body in one hand.
 - Rotate the push-on connectors around the input pin using needle nose pliers. This will clean the crud, and also let you tell if the connections are so loose as to also cause a problem.
- Need more information on your old turntable? Visit www.vinylengine.com . They have an extensive collection of turntable service manuals.
- Why Vinyl? Because it seems to have a higher SAR (Soul to Annoying Artifacts Ratio) than most digital.

Schematics

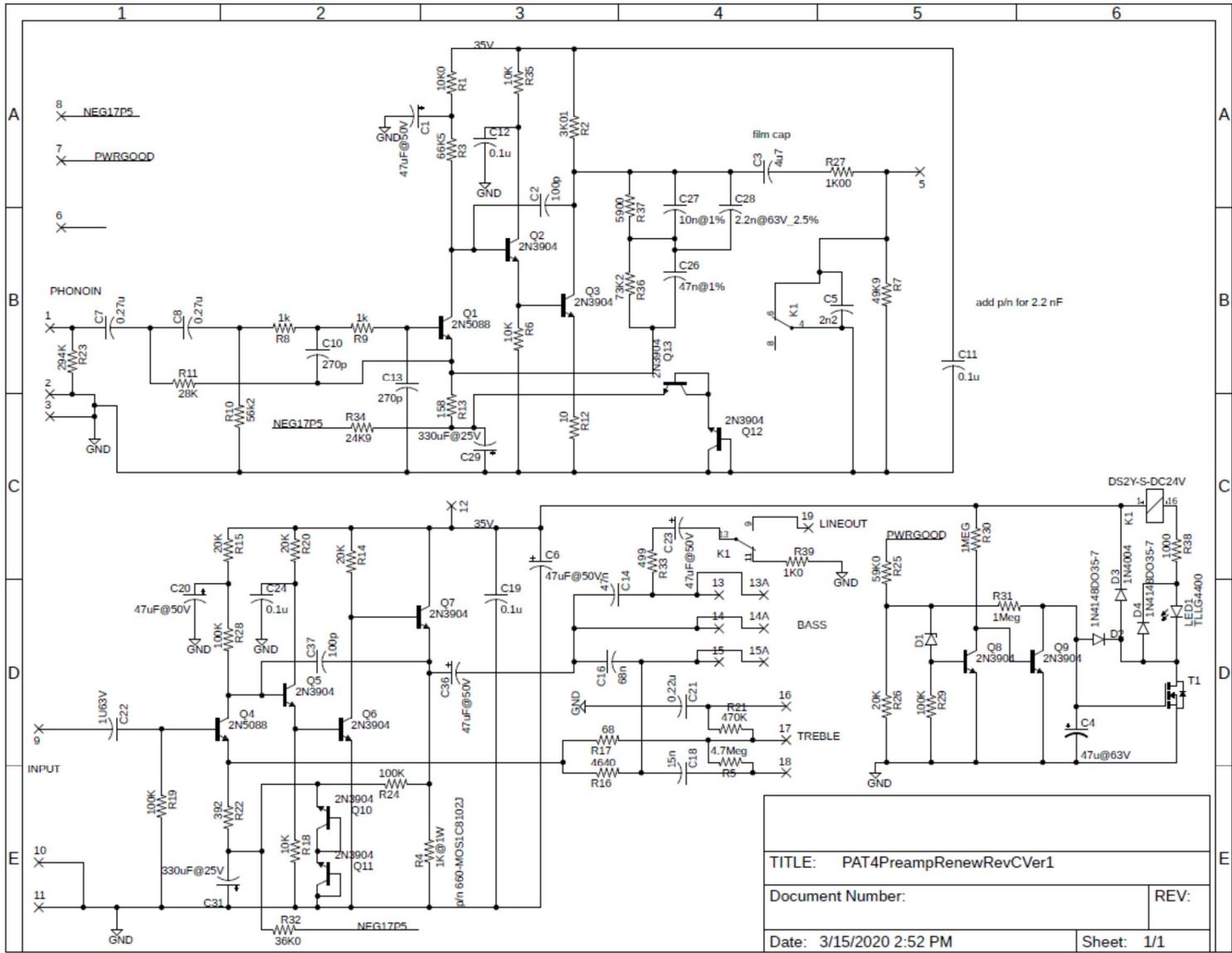

Figure 14-Schematic of the PAT4Renewal Board
 Note that RevCVer1 PCBs add a place for C5, not populated, in parallel with R7

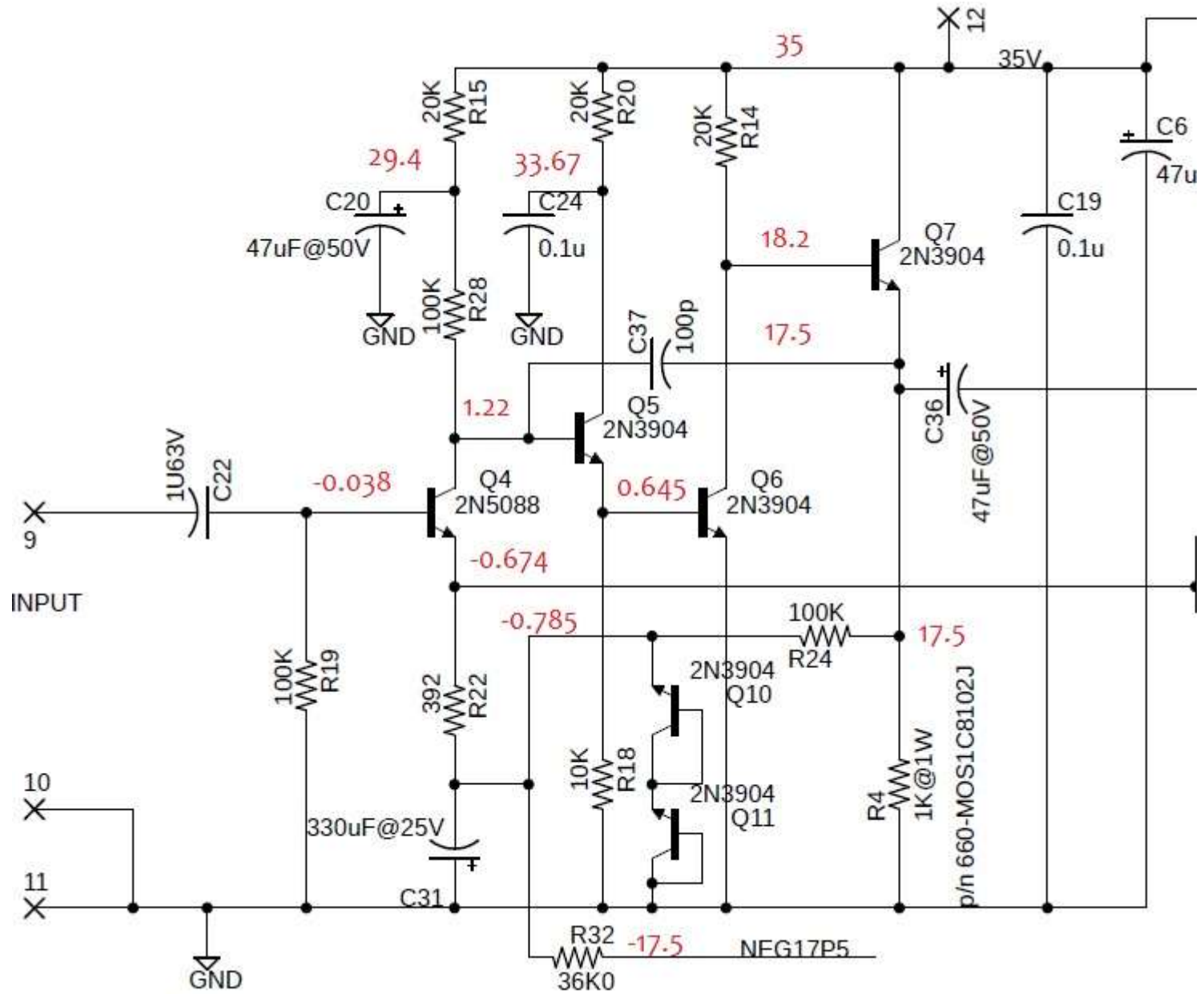

Figure 15-DC voltages on the line stage

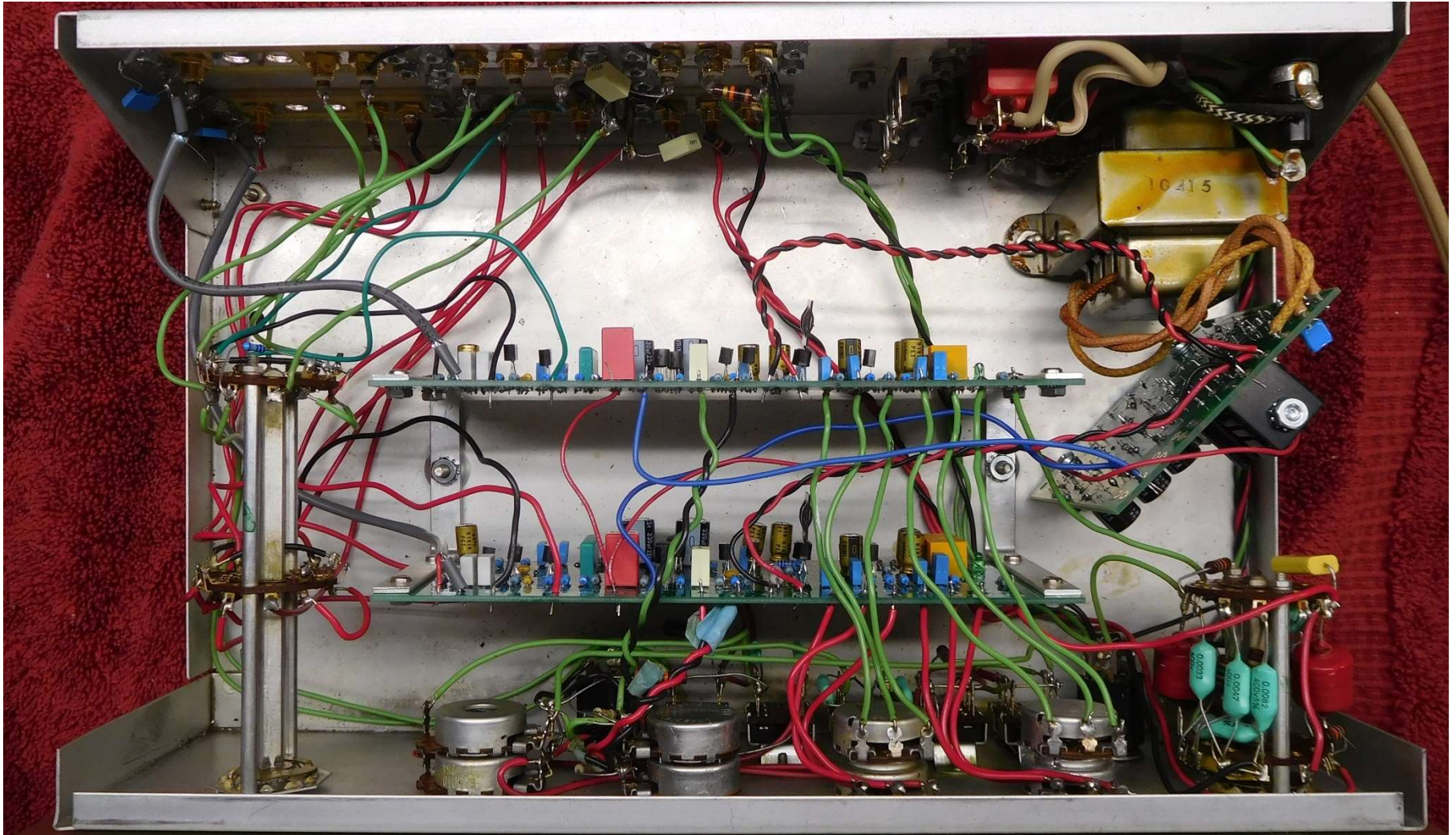
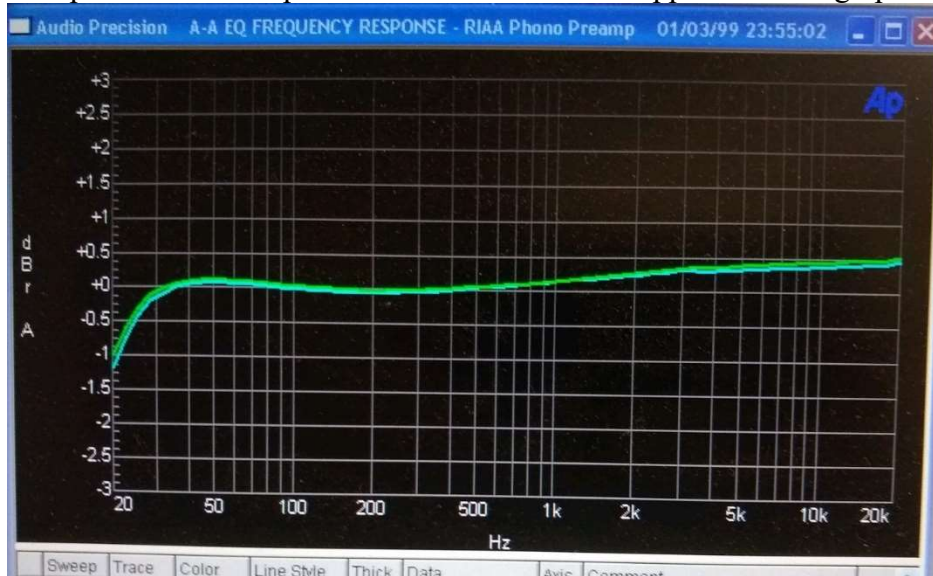

Figure 16-PAT4 with renewal boards installed

Specifications

Phono Stage

Frequency response – typically within a 0.5 dB error band between 20 Hz and 20 kHz, with the exception that the response is -1 dB at 20 Hz in support of the high pass filter.



High Pass Filter (with respect to 1 kHz)

- -1 dB at 20 Hz
- -8 dB at 10 Hz
- -19.7 dB at 5 Hz

Low Pass Filter (with respect to 1 kHz)

- -4.7 dB at 100 kHz
- -11 dB at 500 kHz
- -19 dB at 1 MHz

Gain at 1 kHz – 33.4 dB

Distortion

Input level mV rms	Output level Volts rms	2 nd (dB below output)	3 rd (dB below output)	4 th (dB below output)	5 th (dB below output)
20	0.925	100			
40	1.85	92	117		
60	2.77	89	110		
80	3.7	86	105	121	
100	4.63	83	100	115	128
140	6.47	80	90	100	110

Line Stage

- Clipping level into high impedance – typically greater than 8 volts RMS
- Distortion at 1 kHz, measured in 100K Ohm load

Input level Volts rms	Output level Volts rms	2 nd (dB below output)	3 rd (dB below output)	4 th (dB below output)	5 th (dB below output)
0.316	0.5	102	-	-	-
0.316	1	97	-	-	-
0.316	2	92	-	-	-
1	3	87	-	-	-
1	4	85	117	-	-
1	5	80	103	-	-
1	6	78	95	95	105

Appendix 1: The Toothpick Trick

This appendix describes an easy way to clear the solder from a hole in the PCB. It can also be used to clear the solder from terminals on pots or jacks. Doing so makes it easier to install a new component or reinstall wires that were temporarily removed to allow access to some other component.

All you'll need is a soldering iron and some toothpicks with sharp points. The diameter of the pointed part of the toothpick must be smaller than the diameter of the hole that you're trying to clear.

Heat the solder land on the component side of the board until the solder flows. Insert the toothpick from the component side of the board while pushing and twisting the toothpick. If the solder has melted, the toothpick should push through the board, displacing the solder. Remove the soldering iron, but let the toothpick remain in the hole until the solder has solidified. Now remove the toothpick. There should be a hole through the solder sufficiently large to allow you to insert the component lead or wire.

Sometimes, a bit of the toothpick will break off in the hole. If this happens, use a stiff piece of wire to push the toothpick fragment out of the hole.

Appendix 2 - Preparing a Shielded Cable End

This section tells how to prepare the ends of the shielded cable. This process will be repeated four times, at both ends of both input cables (although the cables will have different overall lengths).

1. Cut the shielded cable to the overall required length.



2. Use a utility knife with a new, sharp blade to cut the plastic jacket of the shielded cable 3/4" back from the end. Hold the blade perpendicular to the cable, and draw it across the cable lightly as you rotate the cable along its long dimension. This creates a scored line through the plastic jacket. With a sharp blade, not much pressure is needed. You may need a bit of practice to get the feel.



3. If you've scored the jacket carefully, you can separate the jacket at the score line without using tools. Pull the insulating jacket off, exposing the cable, showing the foil shield, the drain wire, and the fuzzy string. The result is shown here, with the foil shield showing.



4. Cut off the fuzzy string.



5. Separate and twist the drain wire.

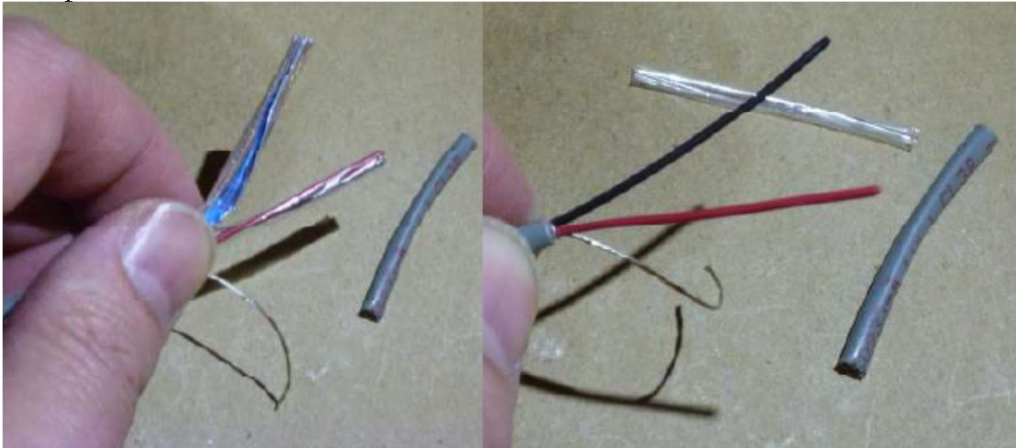

6. Peel back and remove the foil. Remove the plastic wrap from the red and black wires. The drain (bare wire), red, and black wires are exposed now that gray insulating jacket, foil shield, and plastic over-wrap have been removed.
7. To make a shielded cable for a right channel application, pull the black wire out of the shielded cable and leave the red wire for RIGHT channel signals.
8. To make a shielded cable for a LEFT channel application, pull the red wire out of the shielded cable and leave the black wire for LEFT channel signals.
9. Remove 1/4" of insulation from the red wire. Twist its strands tightly. Twist and tin the ends of the red wire (or black wire if preparing a left channel input cable) and the drain wire.
10. Slip about half of the gray outer jacket you removed in the first step over the drain wire. This will keep the bare drain wire from contacting something by accident.

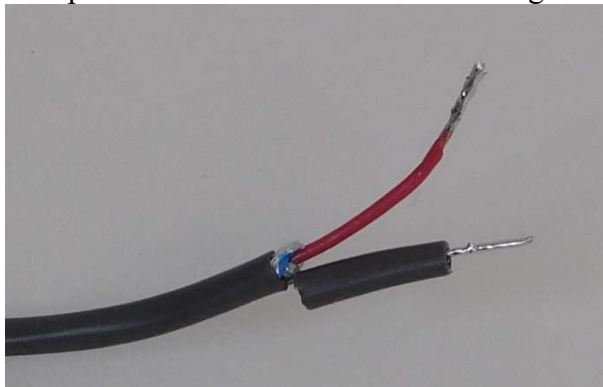

Figure 17- Shield wire end prep completed (right channel)

Appendix 3 - Resistor Color Code



Figure 18-demonstrating the resistor color code

Here's an extreme close-up of a $\frac{1}{4}$ W metal film 20K (20,000) Ohm resistor, designated by the standard resistor color code.

The colors map to numbers:

Color	Number
Black	0
Brown	1
Red	2
Orange	3
Yellow	4
Green	5
Blue	6
Violet	7
Gray	8
White	9

The color band positions have the following meaning:

Position	Meaning
1	Left-most Digit (e.g. most significant)
2	Next digit to the right
3	Next digit to the right.
4	Number of zeros that follow the three digits, unless: <ul style="list-style-type: none"> Band 4 is gold => multiply by 0.1 Band 4 is silver=> multiply by 0.01
5	Tolerance: <ul style="list-style-type: none"> Violet => 0.1% Brown =>1% Red => 2% Gold=> 5% Silver=>10%