

SCA-80(Q) NEW PREAMP BOARDS INSTALLATION MANUAL

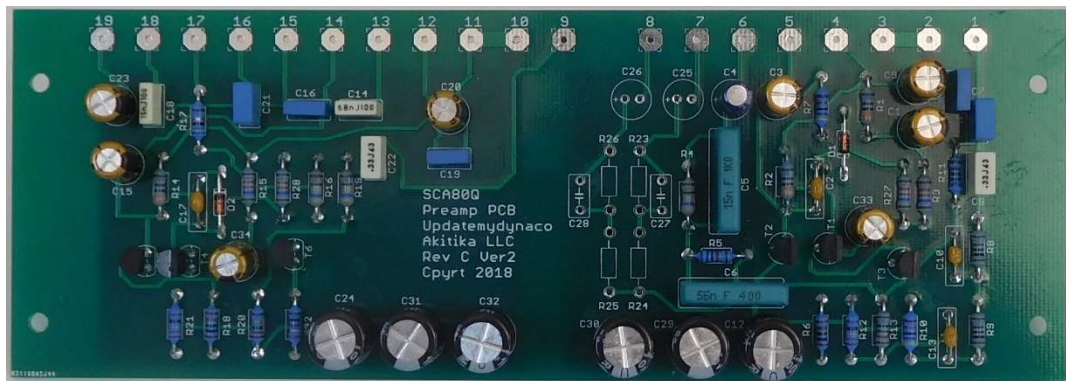

© 2020 Akitika, LLC

All rights reserved

Revision 1p08

June 20, 2020

Table of Contents

Table of Contents	2
Table of Figures	2
Section 1: About This Manual	4
Who Should Attempt these Projects?	4
Tools and Supplies You'll Need	4
Recommended Solder	4
Project Overview	5
Important Safety Notes	5
Section 2: Building the New Preamp PCBs.....	6
Overview.....	6
Use a Soup Bowl.....	6
Install the resistors	7
Install the diodes	8
Install the small capacitors.....	8
Install the larger non-polar capacitors.....	8
Install the Electrolytic capacitors.....	9
Install the transistors	9
Section 3: Removing the Old Preamp PC Boards	10
Removing the Cover	10
Initial Sanity Check.....	10
Preparing to Remove the Circuit Boards	11
Disconnect C14.....	11
Remove the PCB's and the U-brackets.....	11
Inspection and Preliminary Reassembly	11
Remove C14's and Replace with Wires	12
Reinstall the U-bracketed boards	13
Re-attach the wires.....	13
Add the Isolating Resistors	13
Final Sanity Checks	17
Prepare to Reconnect your SCA-80(Q) to your Music System	17
A Note About Hum	17
A Note About Selector Switch Thump	17
Appendix 1: The Toothpick Trick	20

Table of Figures

Figure 1-Use a soup bowl with the contents of 1 channel envelope to build 1 channel.....	6
Figure 2-Silk screen (component) side of PCB	6
Figure 3-match black band on diode to white stripe on PCB	7
Figure 4-Both PCBs reassembled onto U brackets, ready for installation	12
Figure 5-Remove C14, leave terminals 3 and 4 connected, add wire which runs to eyelet 6 (happens for both front and back PC boards)	13
Figure 6-Identifying the switch wires that go to the TAPE OUT RCA jacks	14
Figure 7-Resistor, wire, and heat-shrink tubing.....	15
Figure 8-Isolation resistor installed into front selector wafer signal path	15

Figure 9-Isolation resistor installation is completed.....	16
Figure 10-Schematic of SCA80 new preamp PCB's.....	18
Figure 11-SCA80 Original Wiring	19

Section 1: About This Manual

This manual gives the information you need to replace and upgrade the preamp PC boards of a Dynaco SCA80 or SCA80Q integrated amp. When you install this kit, you'll get better sound as you:

- Build onto a circuit board with a ground plane and decoupling capacitors, assuring greater stability and more rejection of high frequency interference,
- Replace noisy 10% carbon composition resistors with quiet 1% metal film resistors,
- Use 1% capacitors for the equalization in the phono section, assuring much more accurate equalization
- Replace 40+ year old electrolytic capacitors with fresh, new capacitors
- Replace original film capacitors with new film or COG capacitors
- The new boards use a Darlington bootstrap topology that cuts noise and distortion.
- The emitter bypass caps are much bigger, and that keeps the low frequency performance sorted out to the bottom of the audio band, and below.

Who Should Attempt these Projects?

You can build this kit if you can:

1. solder (using normal rosin core solder and a soldering iron),
2. use simple hand tools like screwdrivers, wire cutters, and pliers, and
3. read and follow directions.

It helps if you:

1. know a bit about electronics, or
2. have a friend who knows a bit about electronics
3. can get to YouTube to watch a few helpful videos about the assembly process (not available as of this version of the manual)

Tools and Supplies You'll Need

You'll need the following tools:

1. flat blade screwdrivers for #4 and #6 screws, #2 Philips head screwdriver
2. needle nose pliers (helpful, but not strictly necessary)
3. pencil type soldering iron of 25 to 50 Watts (no huge honking soldering guns or blowtorches)
4. wire cutters and strippers
5. de-soldering tools (see Appendix 1)
6. Magnifying glass, if you're over 42!
7. A multi-meter for measuring Ohms and DC volts is a really good idea, but not strictly necessary. With it, you can double-check your reading of the color code, making sure you get the right resistors in the right location.

Recommended Solder

The kit must be assembled with 60/40 Rosin Core solder. The recommended diameter is 0.032 inches.

Project Overview

Broadly, the project consists of the following steps:

1. Building the new circuit boards.
2. Unplugging the SCA80(Q) and removing the cover.
3. Labeling, then de-soldering all the wires from each preamp circuit board. Each kit comes with a supplied set of labels to mark the wires, making it easy to get the wires back in the right places.
4. Installing the newly built circuit boards.
5. Re-attaching the wires to the circuit boards.
6. Reassembling the SCA80(Q).

Important Safety Notes

By purchasing, using, or assembling this kit, you have agreed to hold AkitikA, LLC harmless for any injuries you may receive in its assembly and/or use. To prevent injuries:

- Wear safety glasses when soldering to prevent eye injuries.
- Always unplug the power before working on the equipment.
- Large capacitors hold lots of energy for a long time. Before you put your hands into the equipment:
 - Pull the AC plug!
 - Wait 1 full minute for the capacitors to discharge!
- Remove jewelry and rings from your hands and wrists, or anything that might dangle into the amplifier.
- If working in the amplifier, keep one hand in your pocket, especially if you're near the power supply or power supply wires. This can prevent serious shocks.
- Build with a buddy nearby. If you've ignored all the previous advice, they can dial 911 or get you to the hospital.

Section 2: Building the New Preamp PCBs

Overview

The listed procedure will be repeated for both left and right channel PC boards. In general, you will:

- Install the indicated component from the component (silk-screen) side.
- Solder the component on the solder side of the PCB.
- Make a check-mark the left or the right channel board as you complete the step.

You may find it convenient to install all resistors of one value first, as they will usually (but not always) be found taped together.

You'll begin with the component that sits closest to the board, and eventually move to the taller components. Begin with the resistors.

Use a Soup Bowl

Empty the contents of ***just one*** of the Channel parts envelopes into a broad, flat soup bowl. It will make it easier to find the parts. This will make building the PC boards more pleasant. It also minimizes the chance of losing a part on the floor.



Figure 1-Use a soup bowl with the contents of 1 channel envelope to build 1 channel

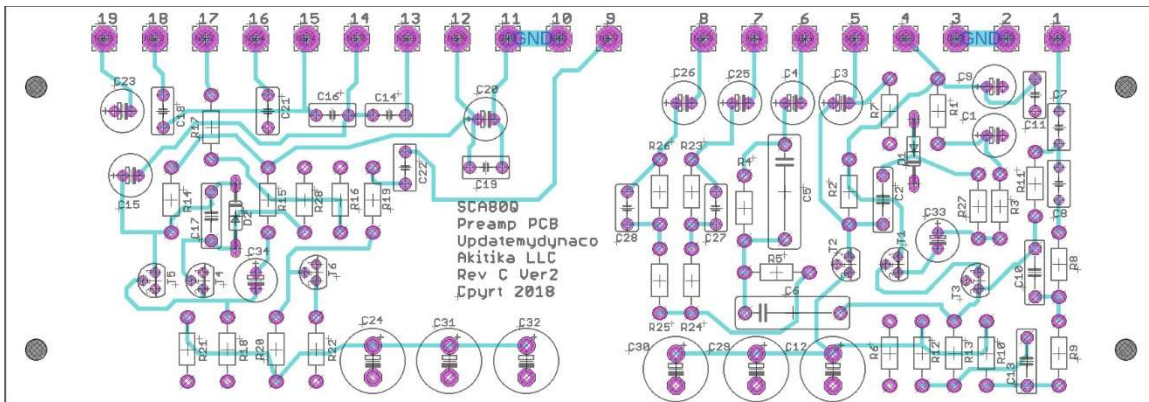

Figure 2-Silk screen (component) side of PCB

Install the resistors

If you like to use a lead-bender for the resistors, 0.4” works well for all the resistors. I strongly recommend using good light, magnification if necessary, and a digital ohm-meter to verify the correct resistor value before you install it.

Desig	Value	Color Code	LEFT Done ✓	RIGHT Done ✓
R1	3300	Orange, Orange, Black, Brown, Brown		
R2	3300	Orange, Orange, Black, Brown, Brown		
R14	3300	Orange, Orange, Black, Brown, Brown		
R3	16K2	Brown, Blue, Red, Red, Brown		
R15	16K2	Brown, Blue, Red, Red, Brown		
R27	16K2	Brown, Blue, Red, Red, Brown		
R28	16K2	Brown, Blue, Red, Red, Brown		
R4	4640	Yellow, Blue, Yellow, Brown, Brown		
R16	4640	Yellow, Blue, Yellow, Brown, Brown		
R19	4640	Yellow, Blue, Yellow, Brown, Brown		
R5	56k	Green, Blue, Black, Red, Brown		
R6	10K	Brown, Black, Black, Red, Brown		
R18	10K	Brown, Black, Black, Red, Brown		
R7	47K	Yellow, Violet, Black, Red, Brown		
R10	47K	Yellow, Violet, Black, Red, Brown		
R8	1k	Brown, Black, Black, Brown, Brown		
R9	1k	Brown, Black, Black, Brown, Brown		
R11	75K	Violet, Green, Black, Red, Brown		
R12	274	Red, Violet, Yellow, Black, Brown		
R21	274	Red, Violet, Yellow, Black, Brown		
R13	121	Brown, Red, Brown, Black, Brown		
R17	68	Blue, Gray, Black, Gold, Brown		
R20	120k	Brown, Red, Black, Orange, Brown		
R22	392	Orange, White, Red, Black, Brown		
R23	-	This resistor is neither provided nor installed		
R24	-	This resistor is neither provided nor installed		
R25	-	This resistor is neither provided nor installed		
R26	-	This resistor is neither provided nor installed		



Figure 3-match black band on diode to white stripe on PCB

Install the diodes

Diodes have a polarity, so orientation is important. The black stripe on the diode must be aligned with the white stripe on the PCB's silkscreen (see Figure 3).

Desig	Value	Marking	LEFT Done ✓	RIGHT Done ✓
D1	1N4148	48		
D2	1N4148	48		

Install the small capacitors

Install these axial-leaded small capacitors. They are non-polar. Either orientation works fine. All the non-polar capacitors in this section have 10% or better tolerance unless otherwise indicated. 1% tolerance capacitors are used to for C5 and C6 to assure excellent phono equalization accuracy.

Desig	Value	Identification (you will need magnification to see these numbers)	LEFT Done ✓	RIGHT Done ✓
C2	100 pF	101		
C17	100 pF	101		
C13	100 pF	101		
C10	220 pF	221		

Install the larger non-polar capacitors

These are radial lead capacitors with a box shape.

Desig	Value	Identification	LEFT Done ✓	RIGHT Done ✓
C7	0.22 μ F	μ 22J100		
C21	0.22 μ F	μ 22J100		
C8	0.33 μ F	0.33J63		
C22	0.33 μ F	0.33J63		
C11	0.1 μ F	μ 1J100		
C16	0.1 μ F	μ 1J100		
C19	0.1 μ F	μ 1J100		
C14	68 nF	68nJ100, or 0.068		
C18	15 nF	15nJ100		
C5	15 nF@1%	15nF 1k0		
C6	56 nF@1%	56nF 400		
C27	-	Not used		
C28	-	Not used		

Install the Electrolytic capacitors

Electrolytic capacitor are polarized. You must observe the correct polarity. Make sure that the negative sign on the capacitor is at the opposite end from the positive sign on the silk-screen. Note in the “Special Instructions” column that some of these capacitors are not used.

Desig	Value	Special Instructions	LEFT Done ✓	RIGHT Done ✓
C1	47 μ F@50V			
C3	47 μ F@50V			
C9	47 μ F@50V			
C15	47 μ F@50V			
C20	47 μ F@50V			
C23	47 μ F@50V			
C33	47 μ F@50V			
C34	47 μ F@50V			
C4	4.7 μ F@50V			
C12	1000 μ F@10V			
C24	1000 μ F@10V			
C29	1000 μ F@10V			
C30	1000 μ F@10V			
C31	1000 μ F@10V			
C32	1000 μ F@10V			
C25		Not used		
C26		Not used		
C27		Not used		
C28		Not used		

Install the transistors

Install the following transistors. Make sure to put the correct type in the correct location. Install them so the top of the transistor package sits about ½” above the PCB. This puts the top of the transistors a little below the tops of the 1000 μ F capacitors. Make sure that the shape and orientation of the body corresponds to the shape and orientation on the silk screen.

Desig	Value	Marking ¹	LEFT Done ✓	RIGHT Done ✓
T1	2N3904, NPN, 40 volts	3904		
T2	2N3904, NPN, 40 volts	3904		
T3	2N5088, NPN, high gain, low noise	5088		
T4	2N3904, NPN, 40 volts	3904		
T5	2N3904, NPN, 40 volts	3904		
T6	2N5088, NPN, high gain, low noise	5088		

¹ There may be more numbers and letters on the package, but the presence of these numbers is enough to correctly identify these parts.

Section 3: Removing the Old Preamp PC Boards

Removing the Cover

1. Disconnect the SCA80(Q) from your music system.
2. Unplug the power cord and allow the SCA80(Q) to sit for one minute before moving on.

Caution: Be sure that the power is unplugged! 120 VAC can be lethal! 240 VAC can be lethal!

3. Remove the 5 screws that hold the cover in place, 2 on the left side and 2 on the right side. There is typically one more screw in the center of the back cover. Do you need more screws? Here's a link:
<https://www.updatemydynaco.com/storeindex.html#5CS>
4. Lift the cover straight up and set it aside in a safe place.

Initial Sanity Check

Before you install the new boards, we'll check the power supply voltages so we can at least be aware of the possible existence of multiple problems.

With the top still off, plug in the AC mains. Turn on the power switch. Set your meter to DC volts. Connect one lead of the meter to circuit common (some people would say ground). Please note that the chassis is circuit common (ground)².

<i>Be careful! These steps are performed with the power connected and turned on!</i>	Done ✓	Done ✓
The voltage on eyelet 4 of both preamp PCB's should measure between 17.5 volts DC (+/-20%) (with respect to ground).	<input type="checkbox"/>	<input type="checkbox"/>
The voltage on eyelet 12 of both preamp PCB's should measure 24 volts DC (+/- 20%) (with respect to ground).	<input type="checkbox"/>	<input type="checkbox"/>

If your voltage readings are significantly different, it could indicate either a power supply problem, or a problem with your original PCB's. There are a couple of possibilities:

1. The voltages are in tolerance. Move on to the next section.
2. The voltages are too low:
 - a. The problem could be with either R41 or R42, or C11, the 3-section silver capacitor. You may have to replace these components (The C11 kit is a good way to do this:
<http://updatemydynaco.com/storeindex.html#SCA80C11>
 - b. The problem could be with components on the preamp circuit boards. Best thought is to continue on to the next section to install the new PC boards.
3. The voltages are too high:
 - a. Typically (but not exclusively) this would be caused by component problems on the PCB. Continue on to install the new PC boards.

² It has no connection to "Green Wire Ground", but that's another story.

Preparing to Remove the Circuit Boards

1. Unplug the power cord and allow the SCA80(Q) to sit for one minute before moving on.

Caution: Be sure that the power is unplugged! 120 VAC can be lethal! 240 VAC can be lethal!

2. The kit is supplied with wire number labels.
3. Mark all the wires that connect to the left channel PCB (it's the one closer to the back of the chassis) using the supplied labels. These labels have an eyelet number, and the letter B, for back. Make sure that the label numbers match the eyelet numbers etched in the copper traces on the solder side of the PCB. This will help you get the preamp back together after the modifications.
4. Desolder all the wires from the left channel PCB after they are labeled. Be careful not to put too much stress on the selector switch.
5. Mark all the wires that connect to the right channel (it's the one closer to the front of the chassis) PCB using the supplied labels. These labels have an eyelet number, and the letter F, for Front. Make sure that the label numbers match the eyelet numbers etched in the copper traces on the solder side of the PCB. This will help you get the preamp back together after the modifications.
6. De-solder all the wires from the right channel PCB after they are labeled. Don't put too much stress on the selector switch as you remove these wires.

Disconnect C14

From your earlier disassembly, you'll note two C14 capacitors, 4.7 μ F, connected to eyelet 6 of each PCB. Desolder or clip C14 near where it connects to eyelet 6. Label their positive ends with 6F and 6B labels. Their negative end connects to pins 3 and 4 of the selector switch. For now, don't disturb the side of these C14's connected to the selector switch decks.

Remove the PCB's and the U-brackets

1. Prepare to remove the two PCB's and the brackets that hold them in place by carefully dressing the wires out of the way,
2. Remove the two 6-32 nuts, lock washers, and screws that hold the U-shaped brackets that retain the circuit boards to the bottom of the chassis.
3. Remove the assembly of the brackets and the two PCB's from the chassis.
4. Remove the 4-40 hardware that holds the PCB's to the U-shaped bracket. Keep track of the lock washers, and remove them so they don't float around inside the preamp or on the PC board.
5. Once both boards are removed, set them aside. They will not be used any further.

Inspection and Preliminary Reassembly

Inspect the new PCB's you built for good solder joints and freedom from solder bridges. Touch up any questionable connections now. It will be painful to have to disassemble things to repair something later.

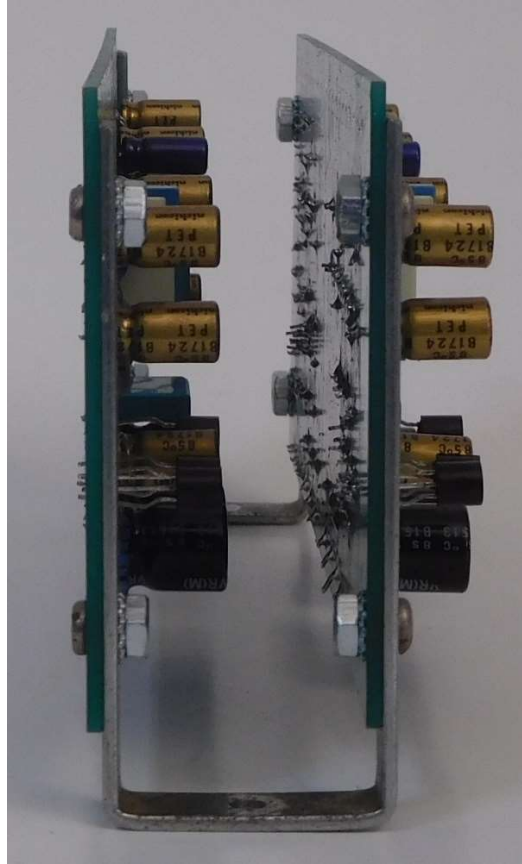

Figure 4-Both PCBs reassembled onto U brackets, ready for installation

Attach the PC boards to the U-shaped bracket. Use the supplied 4-40 keps nuts. They have built-in lockwashers, and will make reassembly easier. Note the placement of the boards with respect to the brackets is a bit different from the stock arrangement. This yields a bit more room between the preamp and the power amp. This is helpful especially if you have replaced the old power amp section with the Updatemydynaco new power amp section.

Remove C14's and Replace with Wires

Remove Right Channel (front) PCB C14:

1. Cut the end of C14 that attaches to pins 3 and 4 of the front deck of the selector switch. Leave Pins 3 and 4 of the selector switch connected.
2. Connect a 4.75" red wire to either pin 3 or pin 4 of the selector switch (it doesn't matter which, since they are connected together).
3. Label the free end of the wire with the 6Fnew label. It will be connected in a later step.

Remove Left Channel (rear) PCB C14:

4. Cut the end of C14 that attaches to pins 3 and 4 of the rear deck of the selector switch. Leave Pins 3 and 4 of the selector switch connected.

5. Connect a 4.75" green wire to either pin 3 or pin 4 of the selector switch (it doesn't matter which, since they are connected together). Note that equivalent of C14 is built into each new PC Board.
6. Label the free end of the wire with the 6Bnew label. It will be connected in a later step.

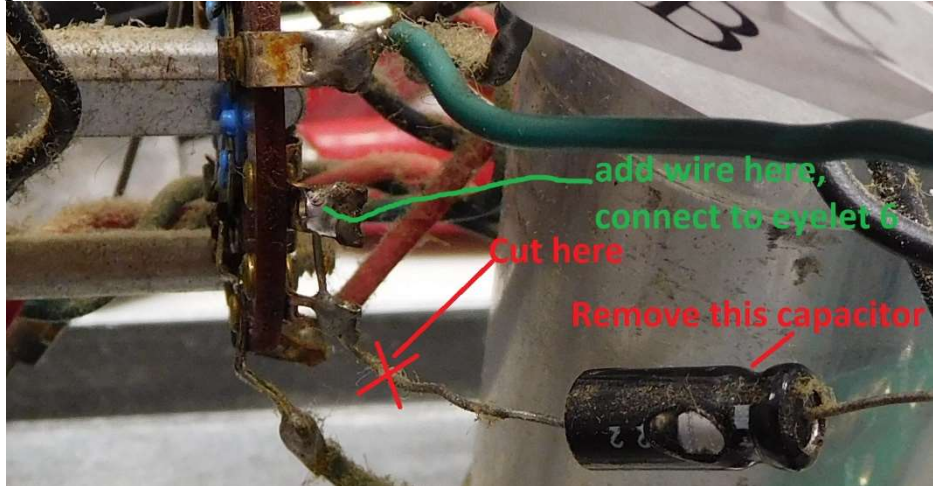

Figure 5-Remove C14, leave terminals 3 and 4 connected, add wire which runs to eyelet 6 (happens for both front and back PC boards)

Reinstall the U-bracketed boards

Screw the assembly of PC-boards and U-shaped bracket back into the SCA-80(Q) chassis. Use the original 6-32 screws and the supplied 6-32 keps nuts. Make sure that the solder side of both PCBs is closest to the front panel.

Re-attach the wires

Re-solder each numbered wire to its proper eyelet and PCB. Here are some hints that may help keep you out of trouble:

1. Remove just one wire label at a time, then re-connect that wire to its proper place.
2. Be gentle...don't yank on the wires, but rather form them carefully.
3. If you need a reminder about where something goes, please refer to Figure 11.
4. Recall that 4 wires are installed into the back boards and continue on to connect to the front board. Those wires were on eyelets 3 (phono preamp ground), 4 (phono preamp 17.5 volts), 11 (line stage ground), and 12 (line stage power, 24 volts).

Add the Isolating Resistors

You'll find two 1K, 1/4W, 1% resistors and a piece of black 1/8" heat-shrink tubing in the Overall kit bag. You'll add these between the selector switch and the TAPE OUT RCA jacks as described below.

1. Desolder (or cut) the wire that runs from the front selector wafer and the rear selector wafer terminals as shown in Figure 6.
2. Trim one of the resistors as shown, and form J-hooks in the wire and one lead of a 1K resistor (color code Brown, black, black, brown, brown).
3. Crimp the J-hooks together and solder the connection.

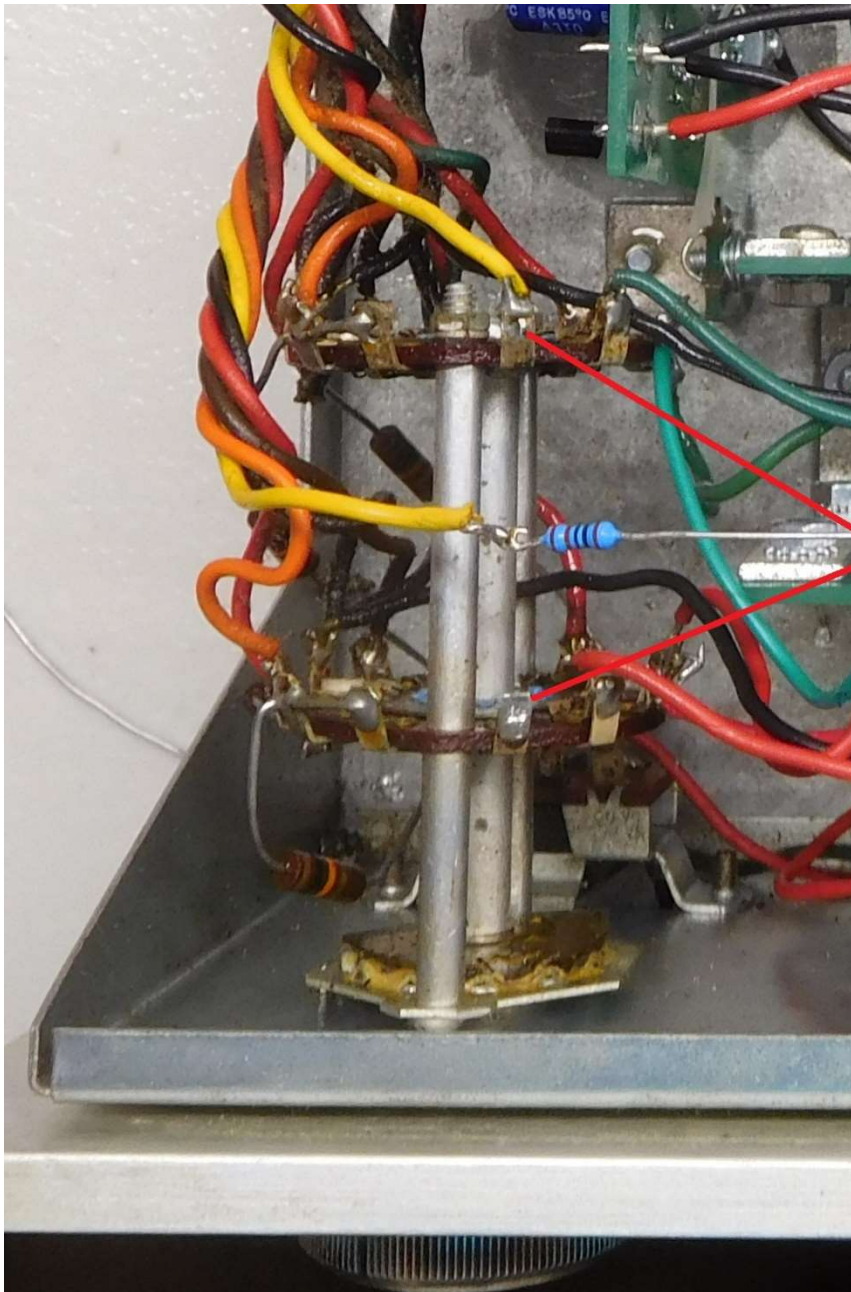

De-solder the wires from these two switch terminals

Figure 6-Identifying the switch wires that go to the TAPE OUT RCA jacks

4. Cut a ½" long piece of black heat-shrink tubing. Slide the heat-shrink tubing over the body of the resistor and the soldered connection. Slide the barrel of your soldering iron over the heat shrink tubing to shrink it in place. See Figure 7.



Figure 7-Resistor, wire, and heat-shrink tubing

5. Solder the free end of the resistor to the terminal from which the wire was removed.

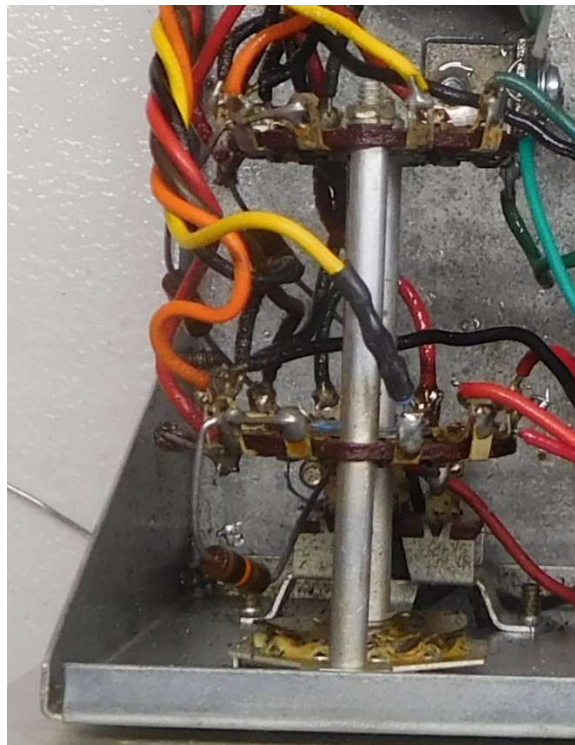

Figure 8-Isolation resistor installed into front selector wafer signal path

Repeat the process with the remaining resistor, heat-shrink tubing, and the back selector wafer. The result is shown in Figure 9.

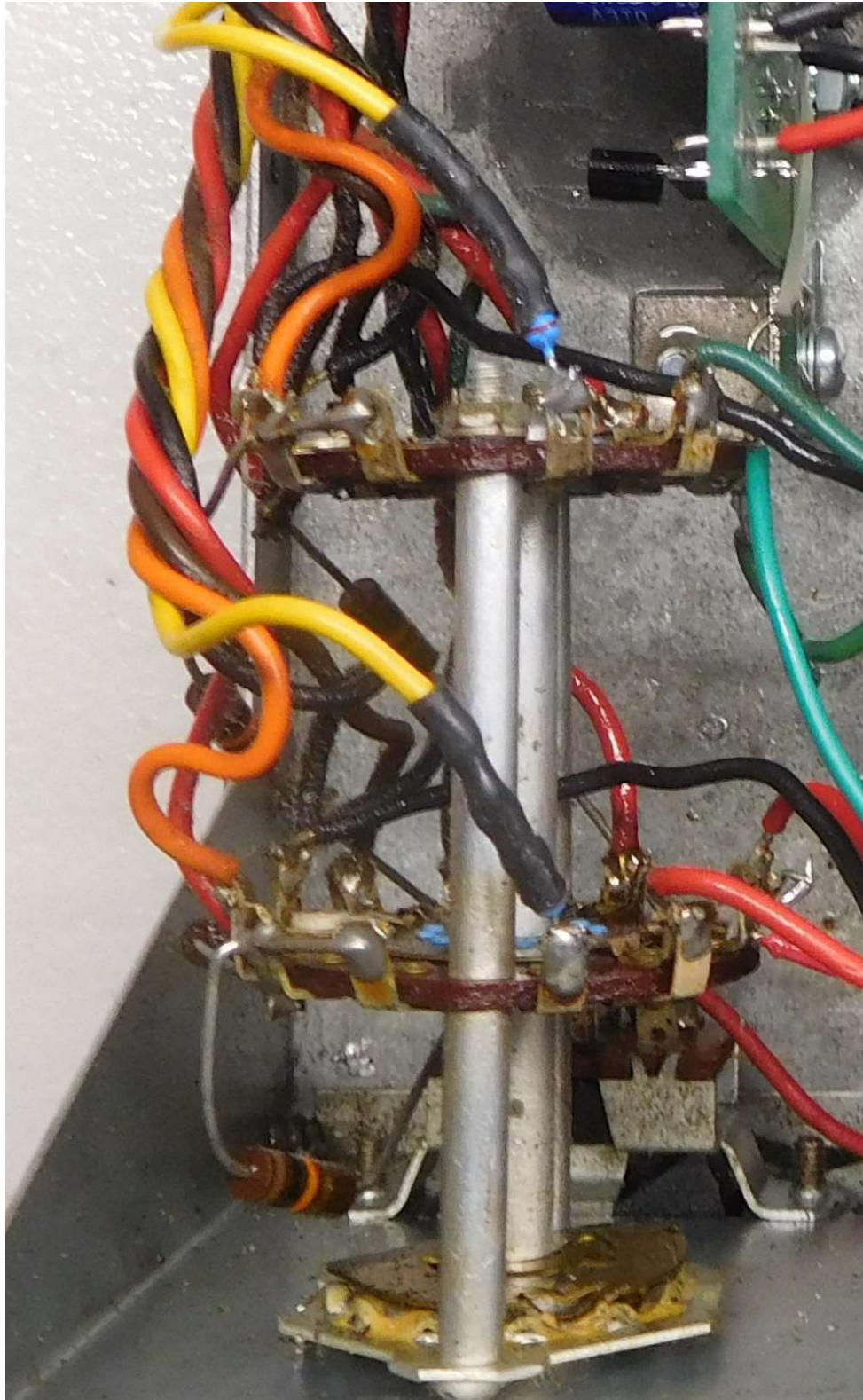

Figure 9-Isolation resistor installation is completed

Final Sanity Checks

Here are a few last tests *before* you reconnect your SCA80(Q) to your music system. With the top still off, plug in the AC mains. Turn on the power switch. Set your meter to DC volts. Connect one lead of the meter to ground.

<i>Be careful! These steps are performed with the power connected and turned on!</i>	Done ✓	Done ✓
The voltage on eyelet 4 of both preamp PCB's should measure between 17.5 volts DC (+/-20%) (with respect to ground).	<input type="checkbox"/>	<input type="checkbox"/>
The voltage on eyelet 12 of both preamp PCB's should measure 24 volts DC (+/- 20%) (with respect to ground).	<input type="checkbox"/>	<input type="checkbox"/>

If your voltage readings are significantly different, it could indicate either a power supply problem, or a problem with your re-assembled PCB's. Re-inspect your work, looking for disconnected or swapped wires.

Prepare to Reconnect your SCA-80(Q) to your Music System

- Turn off the power.
- Remove the AC plug from the wall socket.
- Replace the cover. Before you test your work, it's important to replace the cover. Without the cover in place, there will likely be a lot of hum. With the cover in place, the SCA80(Q) quiets down very nicely (unless of course you have C9 or C11 problems).
- Reinstall the four (five) screws that hold the cover in place.
- Reinstall the SCA80(Q) to your music system.

A Note About Hum

To keep overall hum low, it's very important that the cover be in place with at least one screw tightened down. Assuming that your power supply capacitors are good, the hum will be very low in the upgraded amp so long as the cover is screwed in place.

A Note About Selector Switch Thump

It's always a good idea to turn the volume down before changing the selector switch position. This is especially true when going between the PHONO/SPECIAL settings and any other setting on the selector switch. Please read further for a few useful qualifications.

Selector switch thump will be much worse if your selector switch is dirty. Time after time, I have seen selector switches that show huge thumps get MUCH quieter after spraying the fronts and backs of the selector switch decks with contact cleaner.

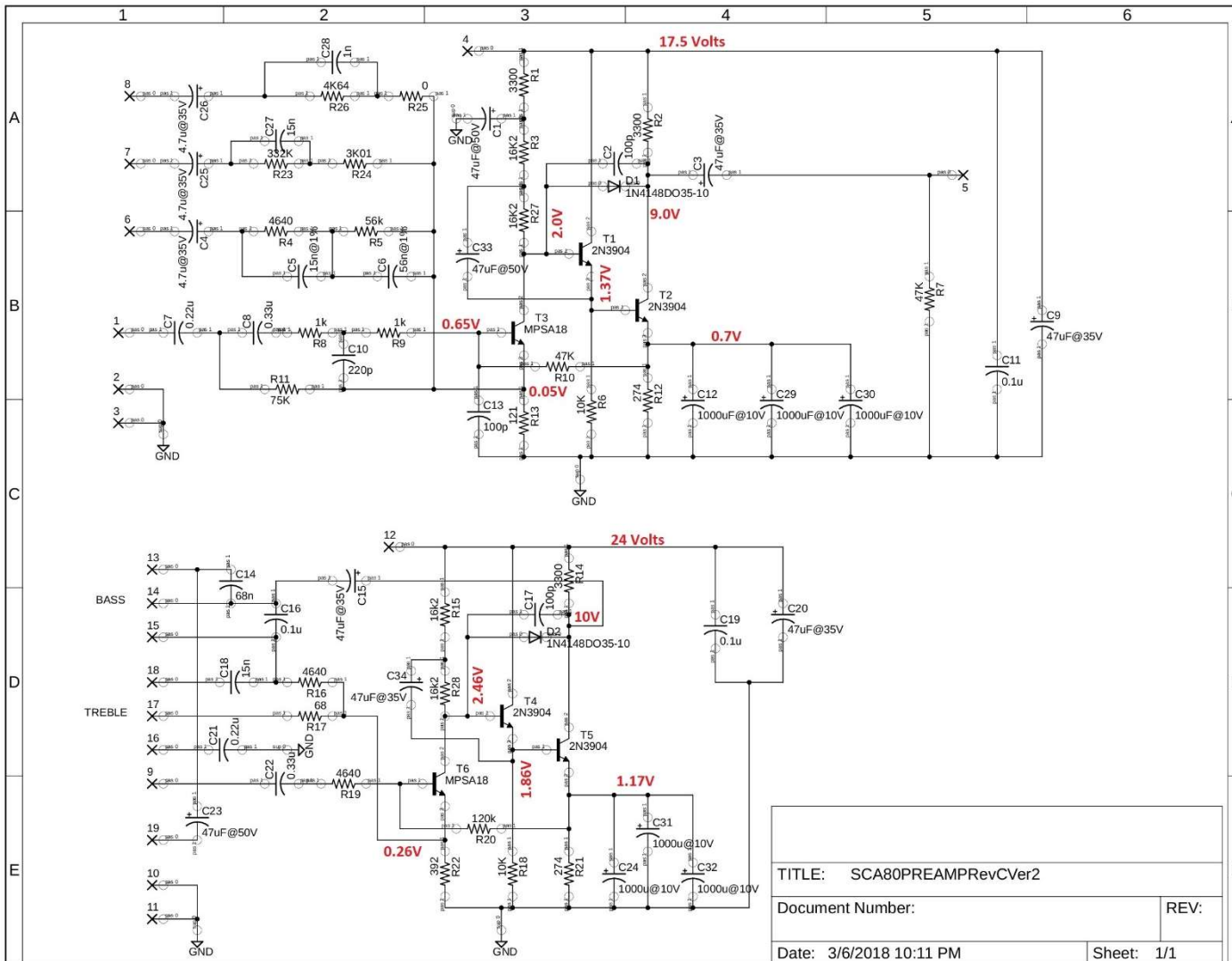

Figure 10-Schematic of SCA80 new preamp PCB's

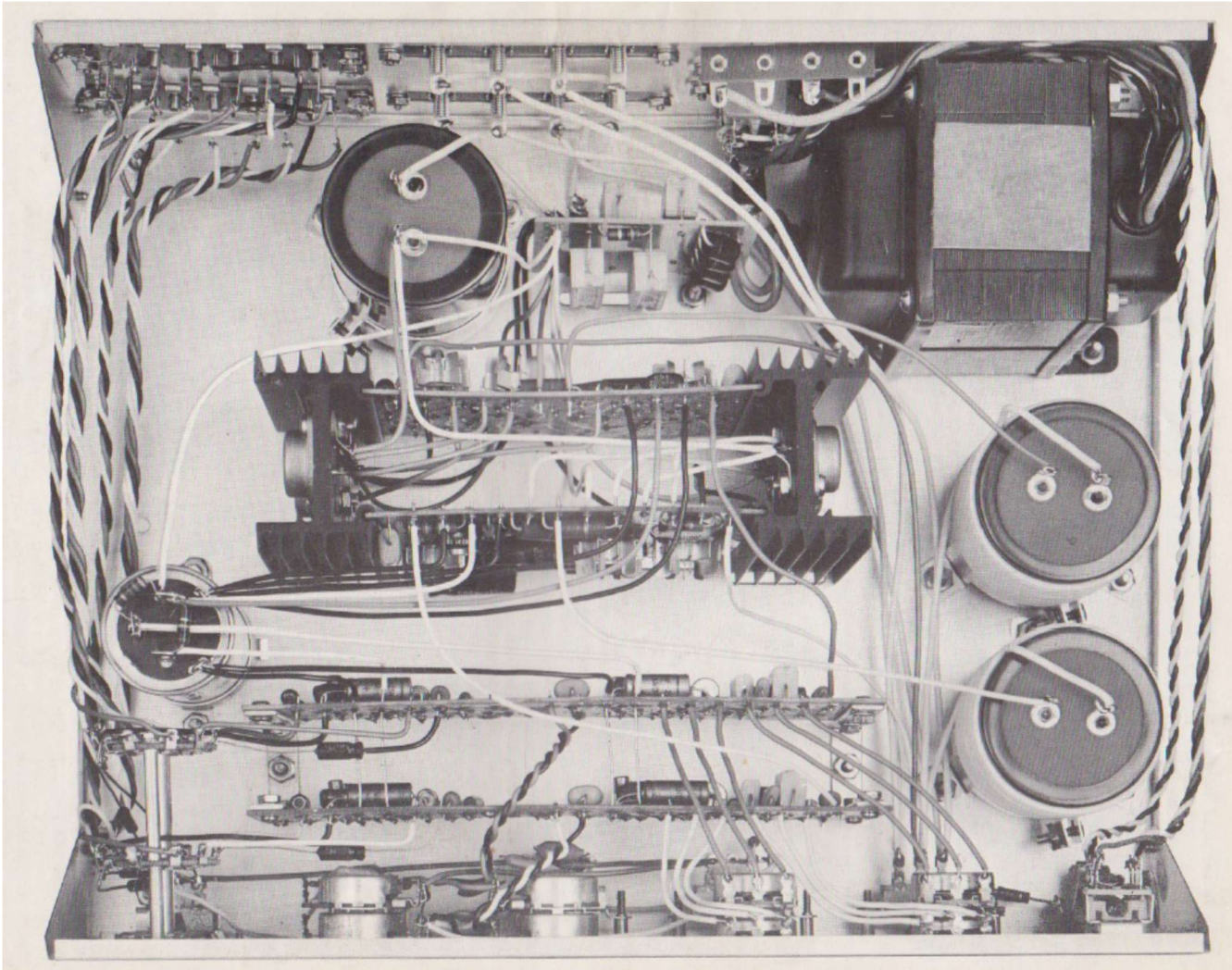

Figure 11-SCA80 Original Wiring

Appendix 1: The Toothpick Trick

This appendix describes an easy way to clear the solder from a hole in the PCB. It can also be used to clear the solder from terminals on pots or jacks. Doing so makes it easier to install a new component, or reinstall wires that were temporarily removed to allow access to some other component.

All you'll need is a soldering iron and some toothpicks with sharp points. The diameter of the pointed part of the toothpick must be smaller than the diameter of the hole that you're trying to clear.

Heat the solder land on the component side of the board until the solder flows. Insert the toothpick from the component side of the board while pushing and twisting the toothpick. If the solder has melted, the toothpick should push through the board, displacing the solder. Remove the soldering iron, but let the toothpick remain in the hole until the solder has solidified. Now remove the toothpick. There should be a hole through the solder sufficiently large to allow you to insert the component lead or wire.

Sometimes, a bit of the toothpick will break off in the hole. If this happens, use a stiff piece of wire to push the toothpick fragment out of the hole.