

UPDATING THE DYNACO STEREO 120 SOLID STATE POWER AMPLIFIER REV B

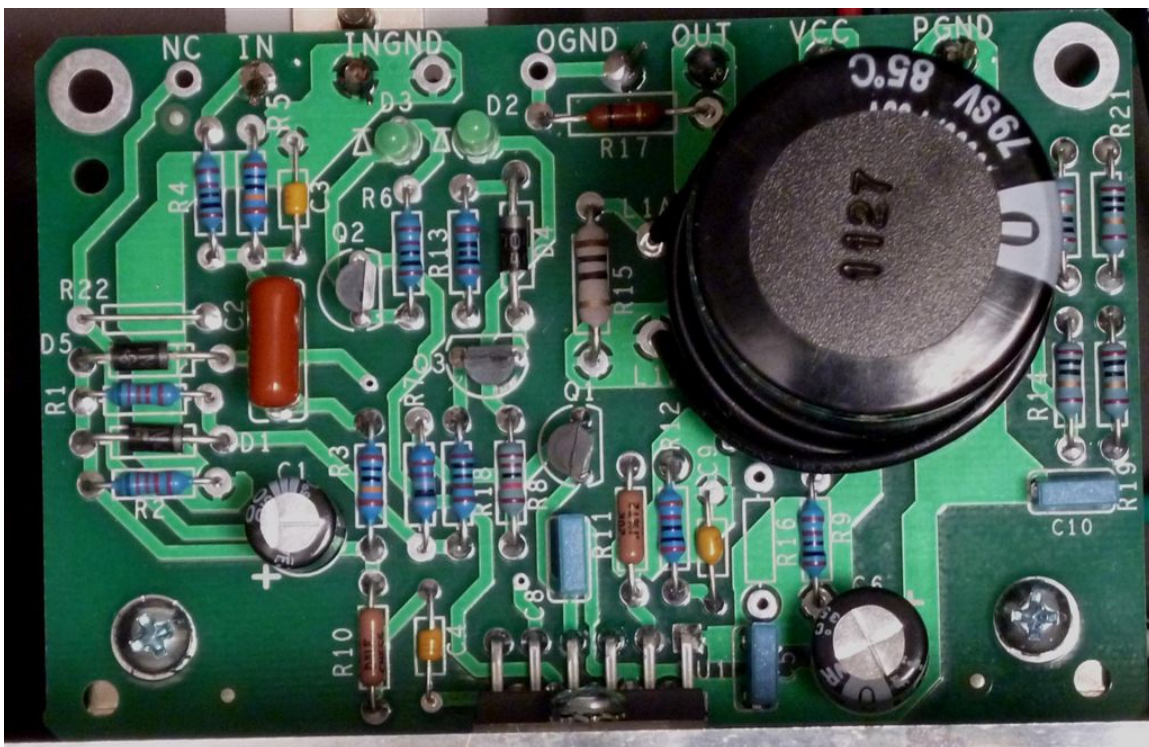

© 2014 Akitika, LLC
All rights reserved
Revision 1.21
August 5, 2014

Table of Contents

Table of Contents	2
Table of Figures	3
Section 1: About this Manual	4
Who Should Attempt this Project?	4
Tools You'll Need.....	4
Project Overview	5
Important Safety Notes	5
About Components	5
Recommended Solder	5
Section 2: Saving the Stuff that Should Be Saved	6
Opening the Amplifier	6
Cutting the wires on the old amplifier modules.....	6
Removing the LEFT channel module.....	6
Removing the RIGHT channel module	7
Removing C7 RIGHT	10
Removing C7 LEFT.....	10
Removing the Output Zobel Networks.....	10
Salvaging the Heat Sinks from the Amplifier Modules.....	12
Section 3: Checking the Stereo 120 Power Supply	12
Prepare and Connect the Test Load	12
Test the Power Supply	13
The Voltage is Much More than 75.6 volts	13
The Voltage is Much Less than 68.4 volts.....	13
There's No Voltage at All.....	14
Section 4: Assembling the Amplifier Circuit Boards	14
Install the Resistors	15
Install the Small Capacitors and the Diodes	17
Last Capacitors and the Transistors	18
Winding the Output Inductor	19
Solder the LM3886 into the Board	20
Final Inspection of the Circuit Board.....	22
Mounting the Updated Amplifier Board to the Heat Sink.....	23
Section 5: Wiring In the Updated Amplifier Modules.....	24
Revise the Grounding System.....	24
Revise the Power System.....	25
Complete the Ground System	26
Wiring the Inputs	26
Wiring the Outputs.....	27
Connecting the Left Channel Amplifier Module	27
Connecting the Right Channel Amplifier Module.....	28
Making the Speaker Binding Posts User Friendly.....	29
Section 6: Testing the Completed Amplifier	29
Test #1.....	29
Test #2.....	30

Test #3.....	30
Test #4.....	30
Resistor Color Code.....	33

Table of Figures

Figure 1-Location of the four screws that hold the cover to the base.....	6
Figure 2-Location diagram for cutting wires.....	8
Figure 3-After the Amplifier Modules have been removed.....	9
Figure 4- Removal of components is completed.....	11
Figure 5- Separating heat sinks and circuit boards.....	12
Figure 6-Connecting a test load to the power supply.....	13
Figure 7-Empty the amplifier components into a soup bowl.....	14
Figure 8-Closeup of Completed Amplifier board (your big cap may look a bit different)	15
Figure 9-First four resistors are installed, leads bent on the back side, soldered, then clipped.....	15
Figure 10-Zero Ohm R22 installation detail.....	17
Figure 11-showing LED cathode orientation.....	18
Figure 12-Starting to wind the output inductor.....	20
Figure 13-finishing step for the output inductor.....	20
Figure 14-Showing method of attaching brackets to the PCB.....	21
Figure 15-Template for checking mounting height of LM3886.....	21
Figure 16-LM3886 installation step three, just the corner pins are soldered.....	22
Figure 17-The LM3886 sits up off the board to avoid shorts between the front and back rows of pins. The body should be at right angles to the circuit board.....	22
Figure 18-Mounting assembled PCB to heat sink.....	23
Figure 19-a completed amplifier module.....	24
Figure 20-Rewiring the Power and Half the Grounds.....	26
Figure 21-completed wiring.....	27
Figure 22-Schematic of amplifier module.....	31
Figure 23-Optional Input Ground Wires are shown in blue.....	32
Figure 24-demonstrating the resistor color code.....	33

Section 1: About this Manual

This manual gives you all the information you need to bring your Solid State Dynaco Stereo 120 Power Amplifier up to date using UpdateMyDynaco replacement modules. This manual covers the Rev B design. It's very similar to the original design, but includes most (but not all of) the improvements made in the Akitika GT-101 design:

- Added components give quiet turn-off even when paired with C12 Upgrade kits (the original design required the quiet turn-off mod to be retro-fit into the board)
- Value changes slightly increase the maximum output power prior to clipping.
- The PCB has a different grounding arrangement which allows the LED's to run more brightly.
- The GT-101 uses 0.1% tolerance gain setting resistors. The modules described herein use standard 1% tolerance gain setting resistors.

The only part of your Stereo 120 that really needs to work is the power supply. With this kit, you'll build good sounding, highly reliable amplifiers to replace the original amplifier modules.

Check www.updatemydynaco.com for *"Hints for Kit Builders"* before you begin assembly

Who Should Attempt this Project?

You can build this kit and update your Dynaco Stereo 120 if you can:

1. solder (using normal rosin core solder and a soldering iron).
2. use simple hand tools like screwdrivers, wire cutters, and pliers.
3. read and follow directions.

It helps if you:

1. know a bit about electronics, or
2. have a friend who knows a bit about electronics
3. can get to YouTube to watch a video about the assembly process

Tools You'll Need

You'll need the following tools to update your Stereo 120:

1. flat blade screwdriver for #6 screws
2. Phillips screwdriver (#2)
3. pliers or nut drivers suitable for #6 hardware (5/16" nut driver or hex wrench)
4. needle nose pliers (helpful, but not strictly necessary)
5. pencil type soldering iron of 25 to 50 Watts (no huge honking soldering guns or blowtorches)
6. wire cutters and strippers
7. multi-meter (helpful, but not strictly necessary)
8. magnifying glass, to verify identification codes on the 3 COG capacitors

Project Overview

The project consists of the following steps:

1. Removing the old amplifier modules, saving some parts for re-use.
2. Checking out the old Dynaco Stereo 120 power supply.
3. Assembling the updated amplifier module PC Boards.
4. Mounting the updated amplifier modules to the heat sinks.
5. Wiring in the updated amplifier modules.

Important Safety Notes

By purchasing this kit, you have agreed to hold Akitika, LLC harmless for any injuries you may receive in its assembly and/or use. To prevent injuries:

- Wear safety glasses when soldering to prevent eye injuries.
- Always unplug the power before working on the amplifier.
- Large capacitors hold lots of energy for a long time. Before you put your hands into the amplifier:
 - Pull the AC plug!
 - Wait 1 full minute for the capacitors to discharge!
- Remove jewelry and rings from your hands and wrists, or anything that might dangle into the amplifier.
- If working in the amplifier, keep one hand in your pocket, especially if you're near the power supply or power supply wires. This can prevent serious shocks.
- Build with a buddy nearby. If you've ignored all the previous advice, they can dial 911 or get you to the hospital.

About Components

We reserve the right to make design/or component changes at any time without prior notification.

Recommended Solder

The kit must be assembled with 60/40 Rosin Core solder. The recommended diameter is 0.032 inches. Among many such sources of solder, I have used Radio Shack part number 64-009. It contains 8 oz. of solder, which is much more than you'll need to assemble the kit.

Section 2: Saving the Stuff that Should Be Saved

Opening the Amplifier

1. *Make sure the amplifier is unplugged. If it was recently powered allow the amp to sit for one full minute before proceeding.*
2. Remove the four screws along the outside edge of the bottom that hold the cover in place (see Figure 1).

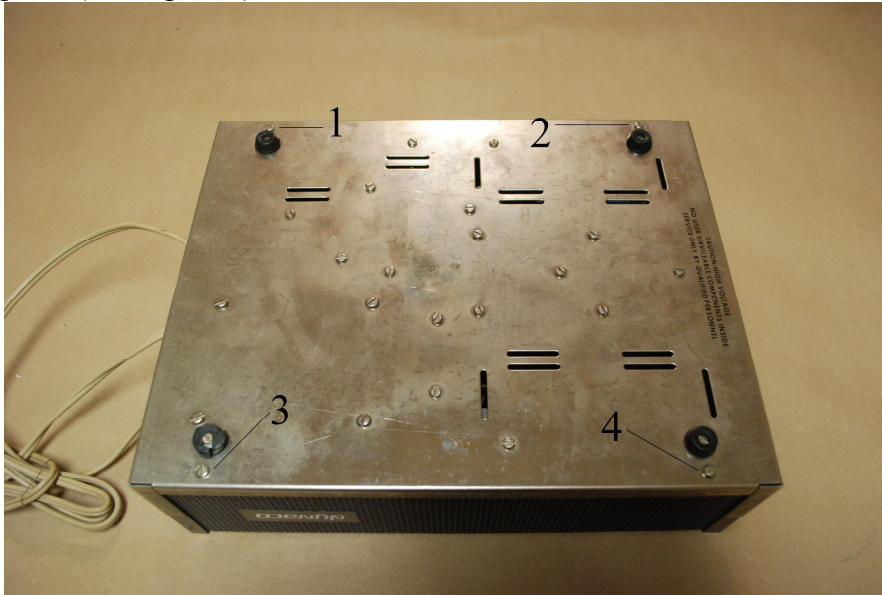

Figure 1-Location of the four screws that hold the cover to the base

3. Holding both the top and bottom of the amplifier, flip it over.
4. Lift the perforated metal top off of the amplifier.

Cutting the wires on the old amplifier modules

Refer to Figure 2. It shows where the wires must be cut to remove the old amplifier modules. Those cuts are detailed in the text below. Each cut is marked by an X.

Removing the LEFT channel module

1. To remove the LEFT channel module, cut the following wires close to the end that connects to the LEFT channel PC-14 module. Make only one cut per wire, leaving the wire attached at the end farthest from the LEFT PC-14 module.
 - a. Eyelets 8, 9, 10, 11, 12, and 13
2. Cut the wire that attaches to Eyelet 5 of the PC-15 power supply circuit board close to the PC-15 circuit board.
3. Loosen the two screws that hold the left channel heat sink in place (note that one of the screws holds a mounting foot¹). Save the hardware for later re-use.
4. Cut the red wire that connects to Q5's collector, close to the lug. Although there are multiple wires on the collector, only cut the wire that connects to C12.

¹ If your mounting feet are falling apart, you can order a replacement set from updatemydynaco.com.

5. Cut the black wire that connects to Q6's emitter, near the emitter. There are two wires on the emitter...you need only cut the wire that runs to the black left speaker binding post.

Save the LEFT module and mounting hardware. We will re-use the heat-sink and some other bits as described in "Salvaging the heat sinks from the amplifier modules".

Removing the RIGHT channel module

6. To remove the RIGHT channel module, cut the following wires close to the end that connects to the RIGHT channel PC-14 module. Make only one cut per wire, leaving the wire attached at the end farthest from the RIGHT PC-14 module.
 - a. Eyelets 8, 9, 10, 11, 12, and 13
7. Loosen the two screws that hold the RIGHT channel heat sink in place (note that one of the screws holds a mounting foot²). Save the hardware for later re-use.
8. Cut the red wire that connects to Q5's collector, close to the lug. Although there are multiple wires on the collector, only cut the wire that connects to C12.
9. Cut the black wire that connects to Q6's emitter, near the emitter. There are two wires on the emitter...you need only cut the wire that runs to the black RIGHT speaker binding post.

Save the RIGHT module and mounting hardware. We will re-use the heat-sink and some of the other bits as described in "Salvaging the heat sinks from the amplifier modules".

² If your mounting feet are falling apart, you can order a replacement set from updatemydynaco.com.

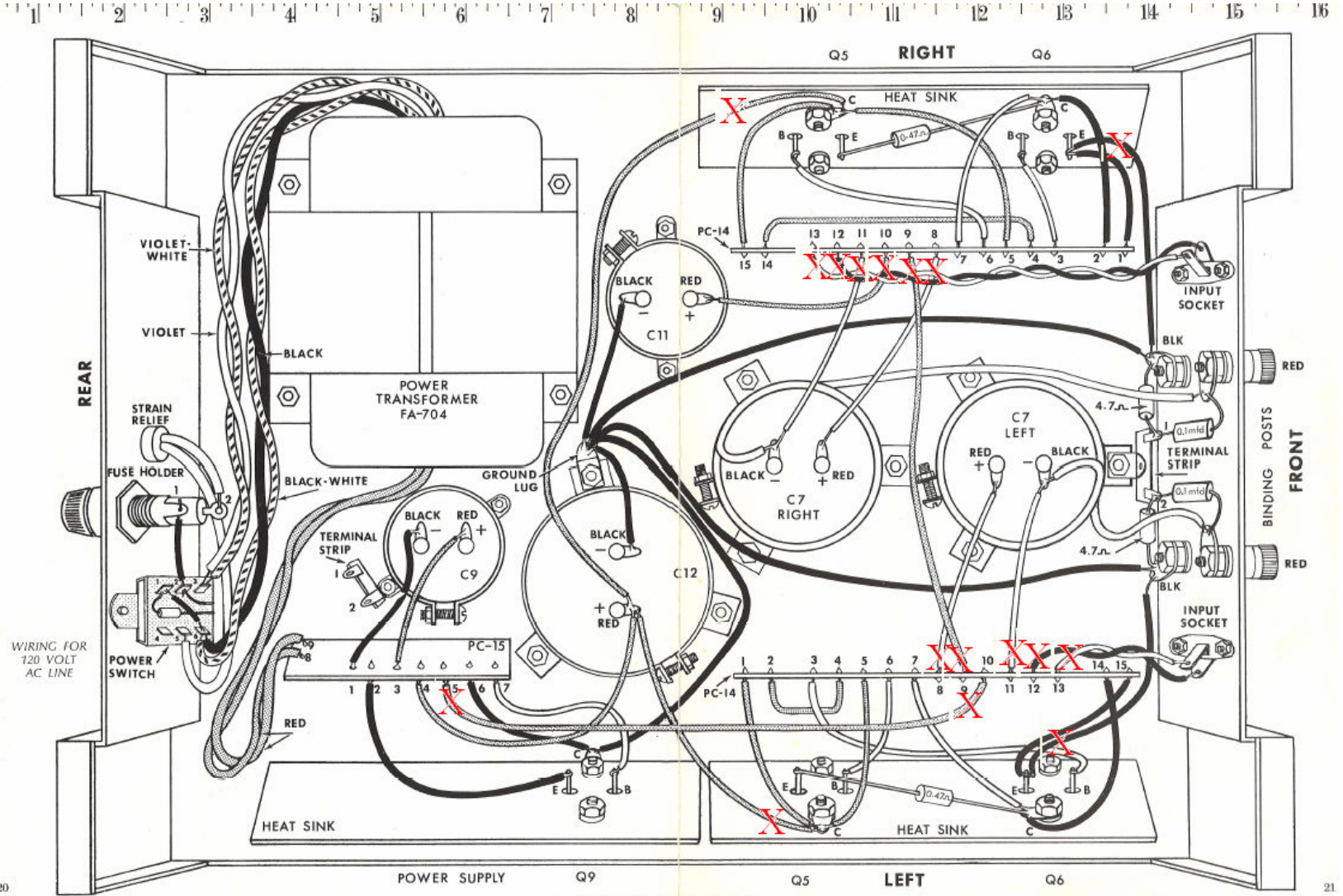

PICTORIAL DIAGRAM

Figure 2-Location diagram for cutting wires

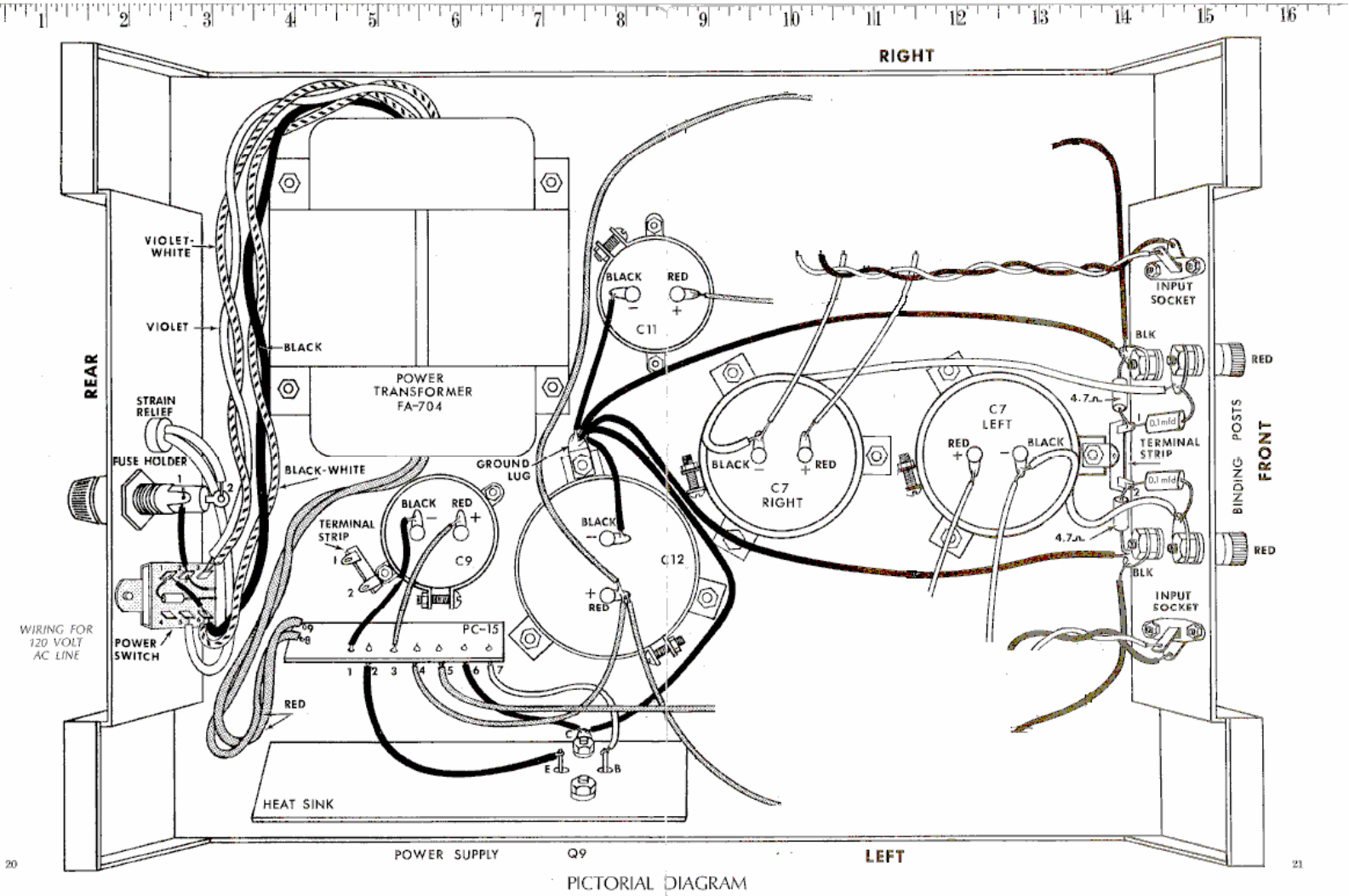

Figure 3-After the Amplifier Modules have been removed

Removing C7 RIGHT

1. Remove the 3 sets of #6 hardware that hold C7 RIGHT to the bottom of the chassis.
2. Unroll one foot of the wire that's wrapped around C7 RIGHT and connects to the RIGHT RED Binding post.
3. Cut this wire near C7 RIGHT so that about 1 foot of wire remains connected to the RIGHT RED Binding post.

Removing C7 LEFT

4. Remove the 3 sets of #6 hardware that hold C7 LEFT to the bottom of the chassis.
5. Unroll one foot of the wire that's wrapped around C7 LEFT and connects to the LEFT RED Binding post.
6. Cut this wire near C7 LEFT so that about 1 foot of wire remains connected to the LEFT RED Binding post.

Removing the Output Zobel Networks

1. Clip the lead of the 0.1 uF capacitor that connects to the RIGHT RED binding post, near the RIGHT RED Binding post.
2. Clip the lead of the 4.7 Ohm resistor that connects to the RIGHT BLACK binding post, near the RIGHT BLACK binding post.
3. Clip the lead of the 0.1 uF capacitor that connects to the LEFT RED binding post, near the LEFT RED Binding post.
4. Clip the lead of the 4.7 Ohm resistor that connects to the LEFT BLACK binding post, near the LEFT BLACK binding post.
5. Remove the terminal strip and the two attached resistors and capacitors.

Figure 4 shows what the amplifier should look like when you've completed this step.

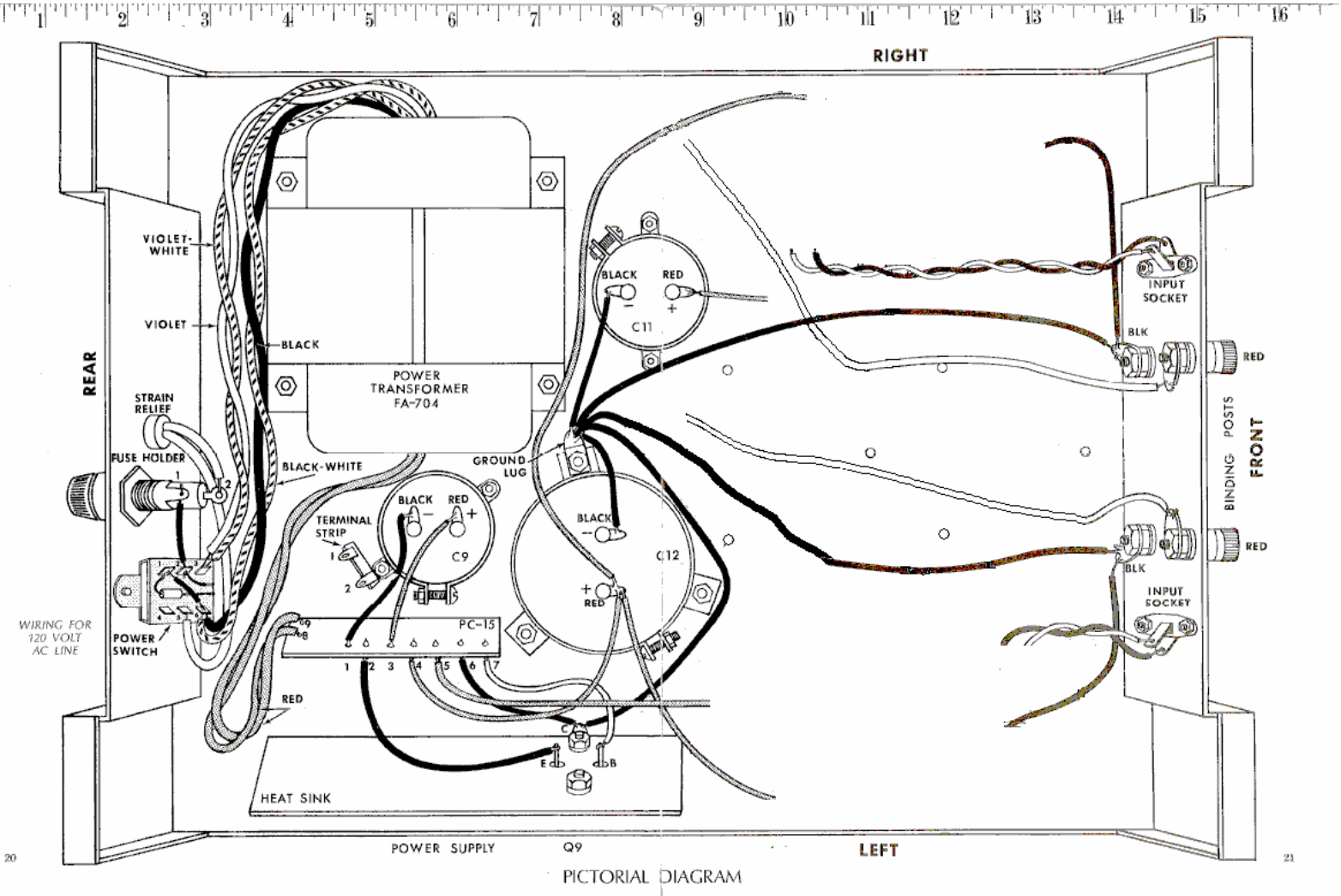

Figure 4- Removal of components is completed

Salvaging the Heat Sinks from the Amplifier Modules

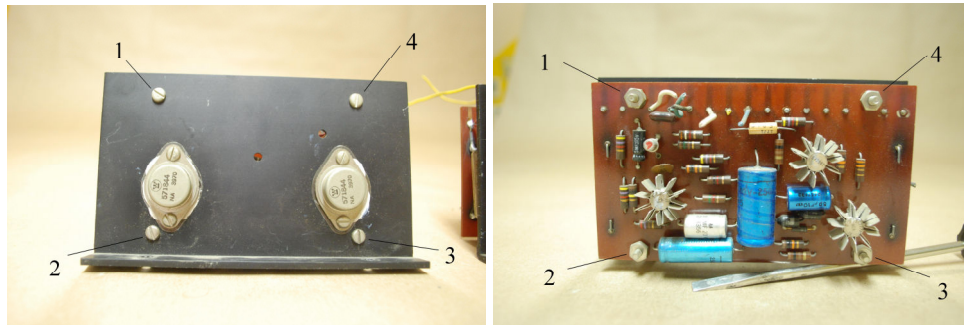

Figure 5- Separating heat sinks and circuit boards

Remove the four numbered nuts, bolts, and standoffs. Cut the wires that connect the power transistors to the circuit board. Remove the four screws that hold the power transistors to the heat sink. Remove the power transistors. Feel free to save everything for a later project. Remove the Mica insulators from the heat sink. After 40 years, they may be pretty stuck on...a single-edged razor slid between the insulator and the heat sink may be the easiest way to separate the two.

Save the old heat-sinks! They're part of the new assembly! Clean off the old thermal compound using Isopropyl Alcohol and paper towels. The best kind of isopropyl alcohol for the job is 90%. The typical 70% is ok, but will take more scrubbing. One motorhead who assembled the kit reports that carburetor cleaner is very effective. When you use Isopropyl alcohol or any other solvent, remember the following:

1. It's flammable! Keep it away from your soldering iron and don't smoke!
2. Use it in a well ventilated area.
3. *Try not to get too much on your skin!*

Section 3: Checking the Stereo 120 Power Supply

The only part of your old Stereo 120 that really needs to work is the power supply. After you've completed the previous section, only the power supply remains in the chassis. This section describes how to verify proper operation of the power supply.

Make sure that the power cord is out, and has been out for at least 1 minute before starting this section.

Prepare and Connect the Test Load

We'll recycle parts of the amplifier boards to make a test load resistor for the power supply. If you know that your power supply and regulator are working correctly, you may skip ahead to Section 4, Building the amplifier boards.

1. Keeping the leads as long as possible, remove two 300 Ohm power resistors from one of the PC-14 circuit boards. If you have any doubts about the resistors, check them with an ohm-meter.
2. Connect the two resistors in series, twisting and soldering.
3. Connect the series resistors across C12. Figure 6 shows how the test circuit will look. The ground side connection is a bit round-about, but it's there none the less.

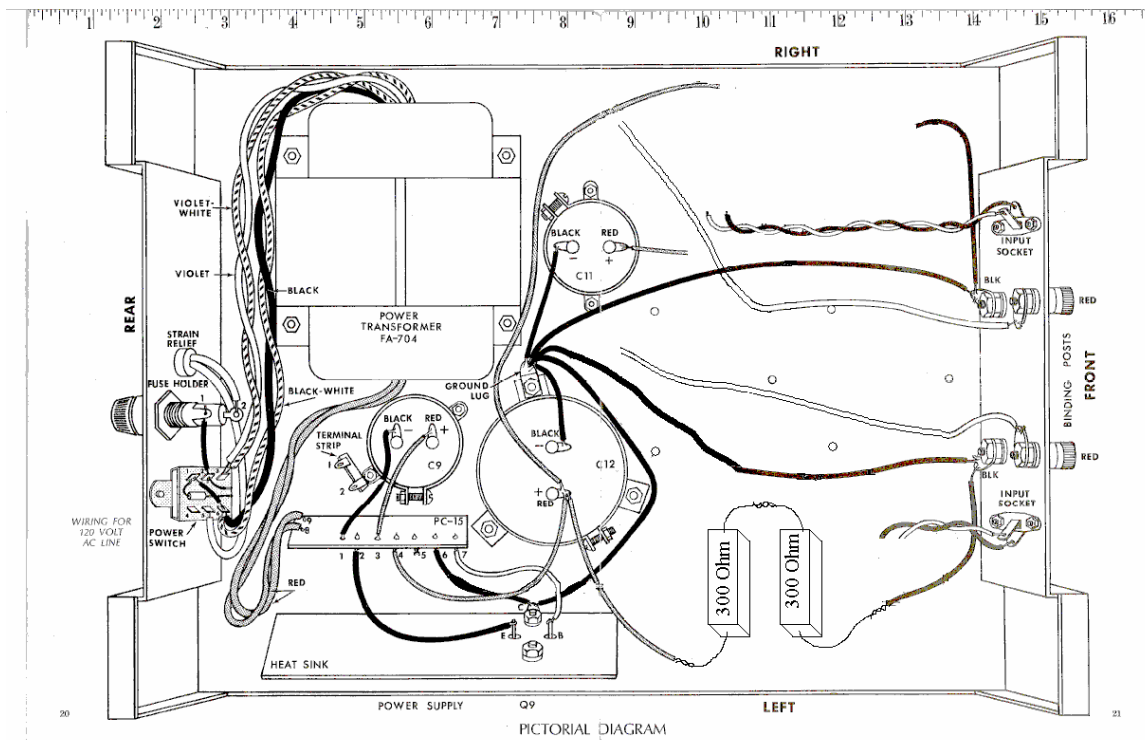

Figure 6-Connecting a test load to the power supply

Test the Power Supply

4. Make sure that neither the resistors nor their connections rest on the chassis. This is important.
5. Make sure that none of the other dangling wires is making contact with anything else.
6. When everyone is clear of the amplifier, plug it in, and turn it on.
7. Measure the DC voltage on the terminals of C12.
8. The voltage should be between 68.4 and 75.6 Volts, with a nominal voltage of 72 Volts. If it falls in this range, your power supply checks out. Remove the load resistors and move onto section 4.

The Voltage is Much More than 75.6 volts

Most likely the pass transistor is shorted. However, repairing the power supply module is beyond the scope of this manual. You can complete Section 4 but don't move on to Section 5 until you have repaired the module. Check www.updatemydynaco.com, the Power Supply Circuit Description, for more information.

The Voltage is Much Less than 68.4 volts

Most likely the pass transistor is open. However, repairing the power supply pass module is beyond the scope of this manual. Don't continue until you have fixed the module. Check www.updatemydynaco.com, the Power Supply Circuit Description, for more information.

There's No Voltage at All

Check:

1. Is the AC socket powered?
2. Is the amp plugged in?
3. Is the power turned on?

Remove the power, check and replace the fuse with a properly rated fuse. Sometimes, fuses just get tired. Sometimes they blow to prevent a disaster. At this point, we're not sure what the case is here.

Maintaining a respectful distance, power the amp again, and observe if the fuse blows. If it blows quickly, unplug the amp, and go to www.updatemydynaco.com, the Power Supply Circuit Description, for more information. The FAQs at the end of the document may be especially helpful.

At this point, if you're scared, confused, or nervous, find someone who knows what they're doing to help you. Above all, be safe!

Section 4: Assembling the Amplifier Circuit Boards

This section details the process of building the amplifier module circuit boards. We start with an overview on this page. Begin by carefully emptying the contents of *one* of the envelopes marked "Akitika Stereo 120 Amp RevB Updatemydynaco" into a broad soup bowl, as shown in Figure 7.

In general, you'll start with the components that lay closest to the board, working your way toward the taller components. You will:

1. Install the resistors
2. Install the small capacitors
3. Install the diodes
4. Install the LEDs
5. Install the medium size capacitors
6. Install the transistors
7. Install the big capacitor
8. Wind and install the output inductor.
9. Install the LM3886.

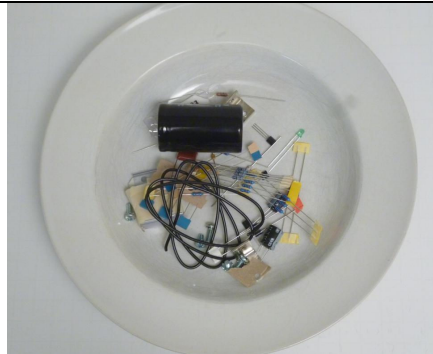

Figure 7-Empty the amplifier components into a soup bowl

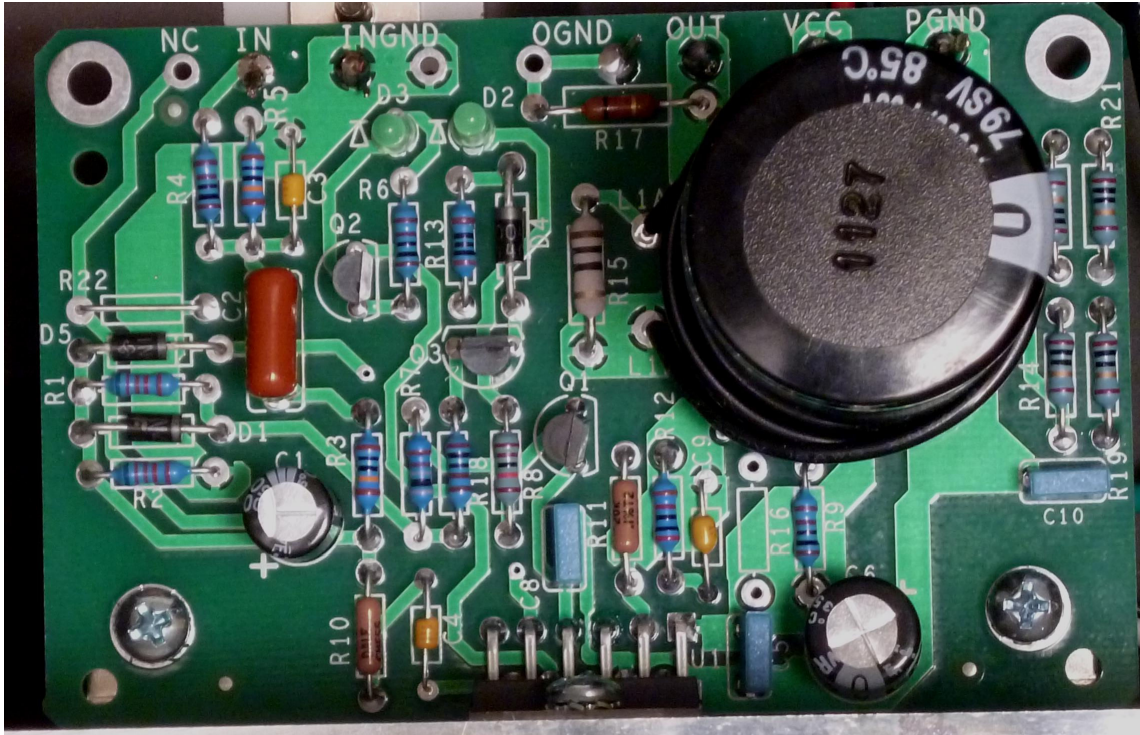

Figure 8-Closeup of Completed Amplifier board (your big cap may look a bit different)

Install the Resistors

In general, you install the resistors by placing the body on the silk screen side of the board, and the leads through the indicated holes. Bend the leads over on the back of the board to keep the resistors from falling out until your solder them in place. Try to bend the leads in a direction that won't lead to solder bridges between traces that should remain disconnected.

We recommend the following procedure:

1. Insert all the resistors of the same value, e.g. R14, R19, R20, and R21.
2. Bend the leads as described above.
3. Solder the leads on the back of the board.
4. clip the leads.

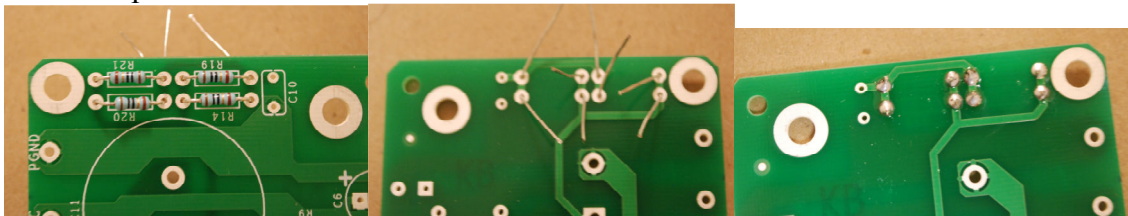

Figure 9-First four resistors are installed, leads bent on the back side, soldered, then clipped.

Turn the page for specific directions about each resistor.

When you have completed this section, there will only be one empty resistor slot, R16, a no-load, which will remain empty.

Keep track of your progress by placing a check-mark in the done column as every resistor is installed. The resistor values can be checked with a meter, or by reading the color code³. Orient the resistor with the fat brown band on the right, then you can read both the Color Code column and the resistor from left to right.

You will build two identical channels. We've provided two Done columns, Done1 for the first channel you build, and Done2 for the second channel. We recommend that you build the channels one at a time, completing the first channel, then returning to this point to build the second channel.

Designation	Value	Color Code	Done 1	Done 2
R14	10	Brown, Black, Black, Gold, Brown		
R19	10	Brown, Black, Black, Gold, Brown		
R20	10	Brown, Black, Black, Gold, Brown		
R21	10	Brown, Black, Black, Gold, Brown		
R13	100	Brown, Black, Black, Black, Brown		
R1	48K7	Yellow, Gray, Violet, Red, Brown		
R2	51K1	Green, Brown, Brown, Red, Brown		
R3	100K	Brown, Black, Black, Orange, Brown		
R5	100K	Brown, Black, Black, Orange, Brown		
R7	9K09	White, Black, White, Brown, Brown		
R8	11K	Brown, Brown, Black, Red, Brown		
R12	20K	Red, Black, Black, Red, Brown		
R4	1K	Brown, Black, Black, Brown, Brown		
R6	1K	Brown, Black, Black, Brown, Brown		
R9	1K	Brown, Black, Black, Brown, Brown		
R18	1K	Brown, Black, Black, Brown, Brown		
R10 ⁴	1K	Brown, Black, Black, Brown, Brown		
R11 ⁵	20K	Red, Black, Black, Red, Brown		
R17	1K (1 Watt) 5%	Brown, Black, Red, Gold (there are less stripes on a 5% resistor) ⁶		
R15	10 (1 Watt) 5%	Brown, Black, Black, Gold (there are less stripes on a 5% resistor). This resistor has a larger body.		
R16		This Location Remains Empty		
R22	0 Ohms	Use one of the cut resistor leads from a previous step to span the R22 mounting holes, making a 0 Ohm resistor.		

Note: R8 and R18 are near each other on the board. Be careful not to mix them up!

³ See “Resistor Color Code” on page 33 to see how to read resistor color codes.

⁴ If your kit has a brown body 1K 0.1% resistor, then you should have been using the GT-101 instructions to build this amplifier module. You can find them at www.akitika.com. Don't worry too much, both directions are very similar.

⁵ Same as previous footnote, but a 20K 0.1% resistor.

⁶ The resistor body of this “1 Watt” resistor seems small to me, but the manufacturer's data sheet swears that it's a 1 Watt resistor. In most cases, it will be called on to dissipate considerably less.

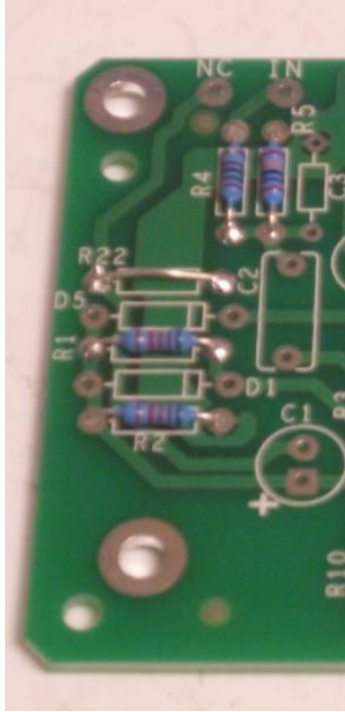

Figure 10-Zero Ohm R22 installation detail

Install the Small Capacitors and the Diodes

Now we'll install the following small capacitors:

Designation	Value	Marking	Done 1	Done 2
C3	220 pF	221		
C4	220 pF	221		
C9	47 pF	470 (some may be marked 47J)		

Here's what these three caps look like (not to scale):

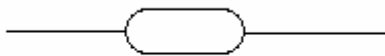

Next we install diodes D1, D4 and D5.

Be careful! Diodes have a polarity. Make sure the band on the diode aligns with the banded end of the silk screen!

Designation	Value	Marking	Done1	Done2
D1	1N4004	4004		
D4	1N4004	4004		
D5	1N4004	4004		

Here's what the diodes look like (not to scale):



Next we install LEDs D2 and D3 (Light Emitting Diodes – the green light from these LEDs will be of medium brightness, and thus visible in a normally lit room.

Be careful! Light Emitting Diodes have a polarity, also! Read carefully to make sure you're putting the diodes in the right way! The cathode of the LED is indicated by a bar (negative sign) molded into the package. On some packages, there is no bar, but seen from the top, the circular outline will have a flat side. That flat side is the cathode. Finally, if the leads are uncut, the shorter of the two leads will be the cathode.

Designation	Value	Marking	Done1	Done2
D2	T1 style	none		
D3	T1 style	none		

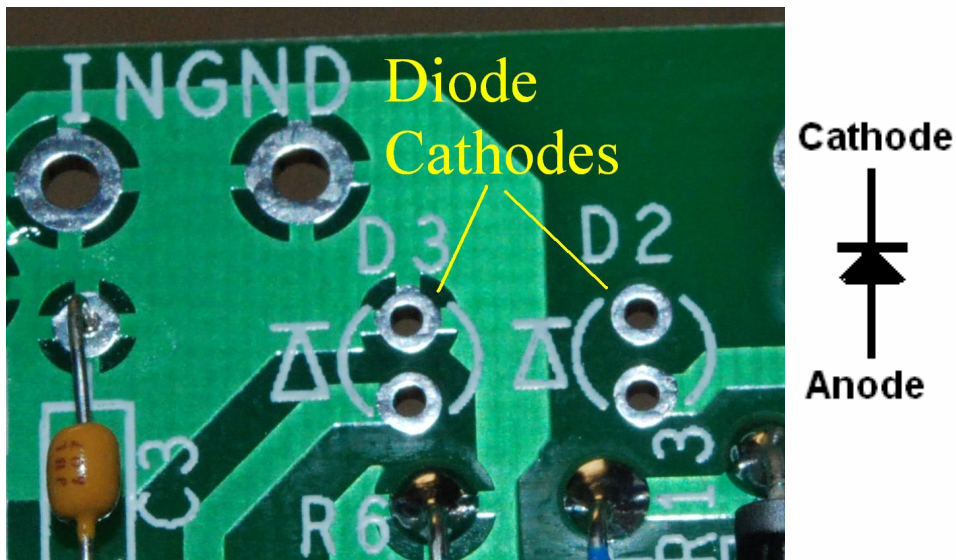

Figure 11-showing LED cathode orientation

Last Capacitors and the Transistors

Now, the medium tall polarized electrolytic capacitors:

C1 and C6 are polarized. Make sure the negative sign on the capacitors faces away from the positive sign on the silk screen!

Designation	Value	Marking	Done 1	Done 2
C1	100 μ F, 50 V	100 μ F, 50 V, and minus sign for polarity		
C6	47 μ F, 100 V	47 μ F, 100 V, and minus sign for polarity		

And the non-polarized capacitors:

Designation	Value	Marking	Done 1	Done 2
C2	1 μ F, 63 V or 100V	105K, 63 V or 100V (pillow shaped mylar capacitor)		
C5	0.1 μ F, 100V	μ 1J100, small blue box shape		
C8	0.1 μ F, 100V	μ 1J100, small blue box shape		
C10	0.1 μ F, 100V	μ 1J100, small blue box shape		

Install the transistors. Spread the outside leads a bit to make it easier to insert them into the board.

Orient the transistor so its body shape matches the silk-screen outline. Leave the top of the transistor about 1/2" off the board! The lead length prevents stress on the body and keeps the transistor safe from too much heat during the soldering operation.

Designation	Value	Marking	Done 1	Done 2
Q1	2N5551, NPN	2N5551		
Q2	2N5551, NPN	2N5551		
Q3	2N5551, NPN	2N5551		

Now install the speaker coupling capacitor:

Watch the polarity! Make sure the minus sign faces away from the plus sign on the silk screen. That puts the minus side of the cap along the outer edge of the circuit board.

Designation	Value	Marking	Done 1	Done 2
C11	3300 uF 63V	3300 uF, 63 WVDC		

The speaker coupling capacitor will either snap or push into place. Verify once more that you have polarity correct, and then solder both speaker terminals to the circuit board. This will probably take more heat, time, and solder than anything you have soldered up to now.

Winding the Output Inductor

This step takes just a bit of finesse, but if you've come this far, you have nothing to worry about. If you're a bit frazzled, take a break before proceeding.

There...feel better? OK, let's go. Just follow these steps, ***measuring the wire length carefully if you want to succeed the on first shot.***

1. Cut a 21 1/2" length of solid wire. A great place to get it is from the output inductors wound around the old Dynaco output capacitors.
2. Strip back 3/8" of insulation from both ends of the wire. Be careful not to nick the conductors.
3. From the component side, place one stripped end of the wire into the L1A terminal. Route it around the output capacitor as shown in (see Figure 12) Solder the wire into the L1A hole.
4. Wind 5 turns of wire, closely spaced, so it looks like Figure 13. When you get to the end of the coil, fold the end across the existing turns, toward the L1B hole.
5. Pull the end of the wire through the L1B hole, and solder it on the back of the board.



Figure 12-Starting to wind the output inductor



Figure 13-finishing step for the output inductor

Solder the LM3886 into the Board

This is the last step in stuffing the circuit board. By now, you are pretty good at soldering. Your skill will help you with this step. Just follow the instructions calmly and carefully, and you'll do just fine.

1. You'll start with one small bit of mechanical assembly as shown in Figure 14. Use two #6-32x1/4" Phillips head screws (they have captive lock-washers) to fasten two brackets to the solder side of the amplifier PC board. Watch the bracket orientation, and don't install any more fasteners at this time!
2. With the brackets attached to the PC board, use the template in Figure 15 to check the LM3886 mounting height. If your printer has printed to the correct scale, the square in the figure should be very nearly 1" by 1". Print this page, and set the board and brackets against the page to check the LM3886's height above the board.
3. Match the outline of the LM3886 and the PC board to the drawing. When the match is pretty good, ***solder one corner pin*** of the LM3886. Recheck the match, and ***solder an opposite corner pin*** (see Figure 16). If something has moved, just reheat the corner pins and pull the LM3886 in or out as needed. If you miss a right angle by a little, don't worry. Since you've only soldered two pins down, it's easy enough to reheat those two pins, and move the LM3886 up and down a bit until it sits at the right height.
4. Check your work:
 - a. The LM3886 body should sit up off the board to avoid short circuits between the rows of pins (See Figure 17).

- b. The LM3886 body should sit at right angles to the plane of the board. If the result comes up a bit away from a right angle, don't worry. The mounting system is compliant enough that this won't be a problem.
5. Solder all the remaining pins of the LM3886 to the PCB.

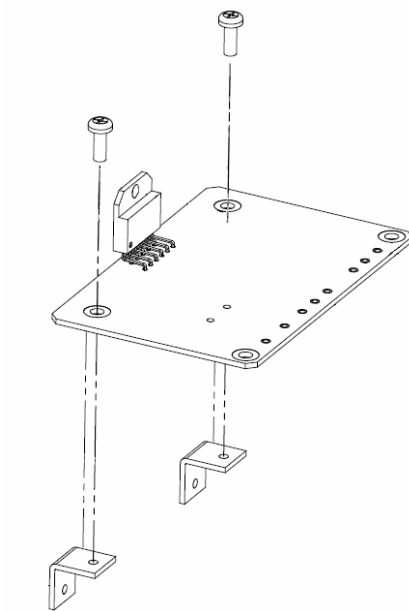

Figure 14-Showing method of attaching brackets to the PCB

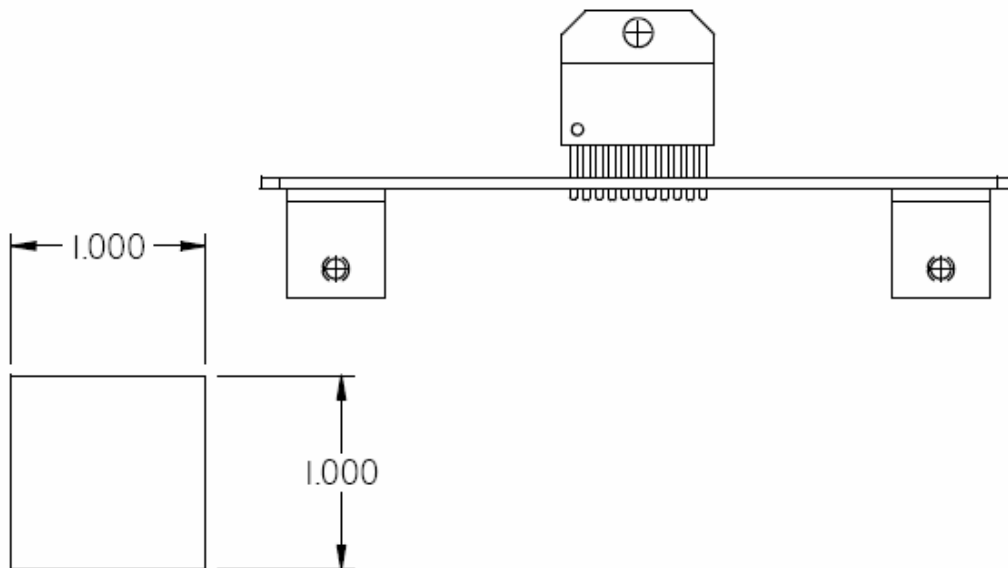

Figure 15-Template for checking mounting height of LM3886

Carefully inspect your soldering. Make sure that all pins of the LM3886 are soldered, and that there are no solder bridges between pins. Inspect the board from both the top and the bottom!

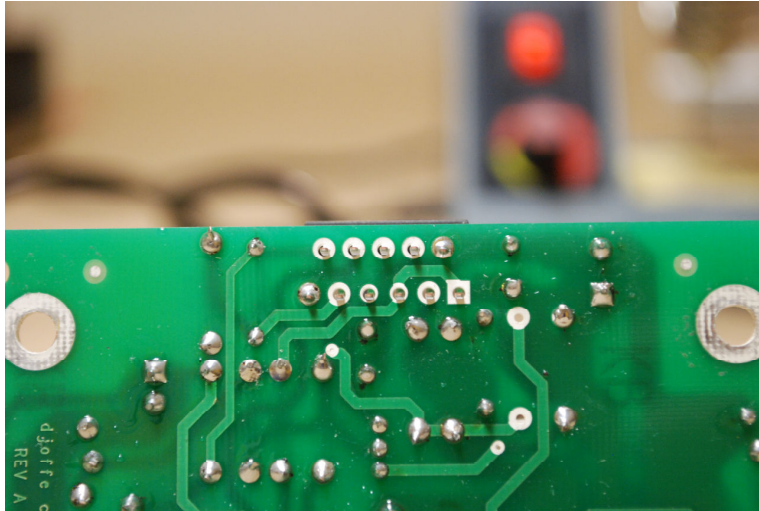

Figure 16-LM3886 installation step three, just the corner pins are soldered



Figure 17-The LM3886 sits up off the board to avoid shorts between the front and back rows of pins. The body should be at right angles to the circuit board

Final Inspection of the Circuit Board

After you've taken a break, look over your completed circuit board(s) one more time. Looking on the component side, double check:

1. polarity (banded end) of D1 and D4 matching the banded end on the silk screen.
2. polarity (flat end, or molded bar end) of LEDs D2 and D3, placed toward the outside edge of the board.

3. polarity of C1 (minus sign away from the indicated plus sign on the silk screen).
4. polarity of C6 (minus sign away from the indicated plus sign on the silk screen).
5. polarity of C11 (minus sign close to the edge of the board).

If you get one of these polarities wrong, there is a good chance that the amplifier won't work, or there will be damage when you power it up.

Look at the solder side of the board. Make sure that:

1. All component leads are soldered (it's easy to forget one or two, and that will cause either unreliable operation, or no operation at all!)
2. There are no solder bridges between pads which should be isolated. Solder bridges may stop the amplifier from working correctly.

Mounting the Updated Amplifier Board to the Heat Sink

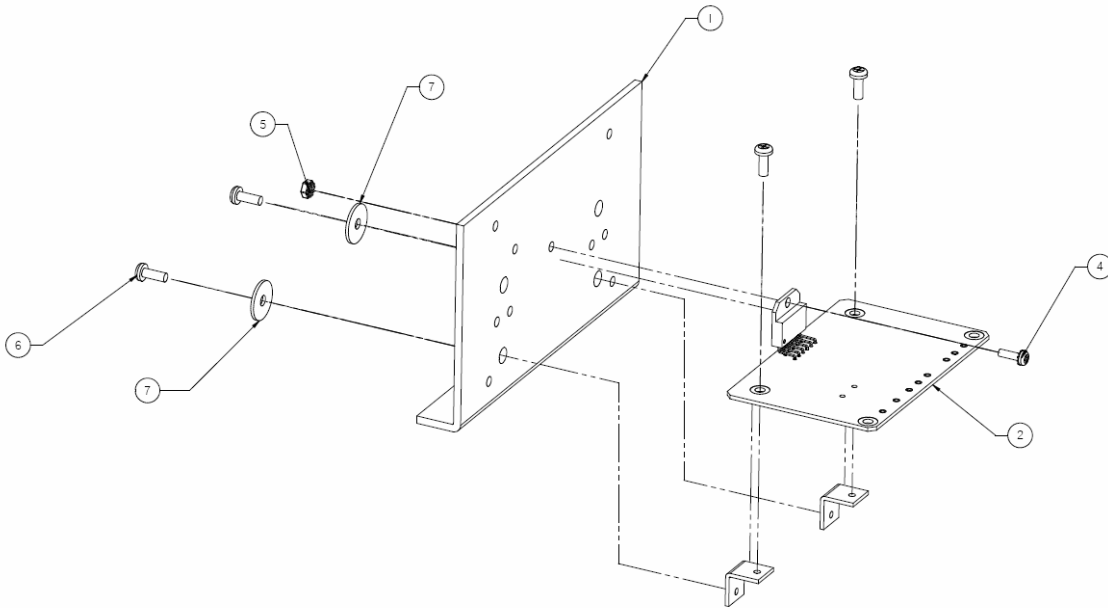

Figure 18-Mounting assembled PCB to heat sink

1. In addition to the assembled circuit board with the mounting brackets in place, have the following items ready:
 - a. The heat sink plate
 - b. 6-32x3/8" screw and nut with captive lock-washer (callouts 4 and 5 in Figure 18).
 - c. Qty 2 of #6 fender washers, and Qty 2 of #6-32x3/8" Phillips head screws with built-in lock washers (callouts 6 and 7 in Figure 18).
 - d. Thermal compound
2. Cut a corner of the 4-gram packet of thermal compound. If you use it appropriately, that's enough to do everything you need. Place a line of thermal compound onto the back of the LM3886. Use your finger to smear the line into a thin film covering on the back of the LM3886. Save the rest of the thermal compound for other steps in the assembly.

3. Assemble the LM3886 and circuit board to the heat-sink plate as shown in Figure 14, using the 6-32 hardware, just finger-tight.
4. Square up the assembly of the circuit board to the heat sink, and use the #6 screws and fender washers to fasten the brackets to the heatsink. The #6 screws and fender washers leave enough wiggle room to make assembly fairly non-critical. Just make everything finger tight at first to make sure it all looks even and fits well without strain.
5. When everything looks good, progressively tighten all the hardware except for the #6 hardware that holds the LM3886 to the heatsink.
6. Finally, tighten the hardware that holds the LM3886 to the heat sink.

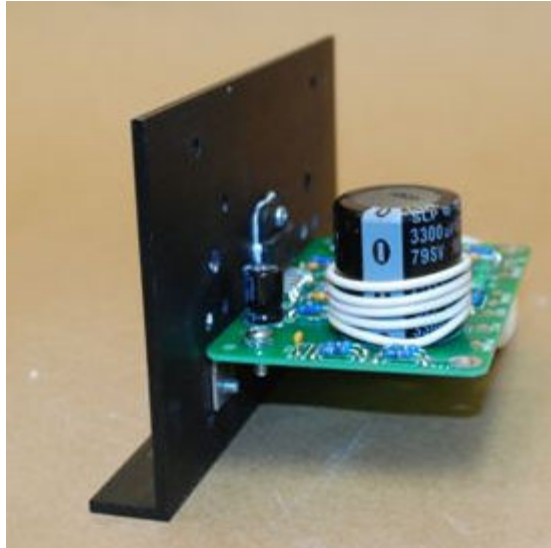

Figure 19-a completed amplifier module

7. Repeat the process to build the amplifier module for the second channel. It begins on page 14.

Section 5: Wiring In the Updated Amplifier Modules

This section gives the steps needed to wire the new modules into your old amplifier.

Here's the plan:

1. Revise the grounding system
2. Revise the power system
3. Complete the grounding system
4. Replace the left and right channel input wiring.
5. Connect all the wires to the amplifier modules.
6. Fasten the amplifier modules in place.

Revise the Grounding System

We're revising the grounding system for two reasons. First, after a number of years, some of the connections may need to be refreshed to make good contact. Second, these changes can reduce the hum to very low levels.

Figure 3 shows the way the wiring was. Figure 20 shows the way things will look at the completion of the next two sub-sections, Revise the Grounding System and Revise the Power System.

1. Remove the nut and bolt that hold the ground lug to the chassis. It is located between C12 and the transformer (Refer to Figure 3).
2. Cut the 5 wires that connect to the ground lug, close to the ground lug. Leave the other end of these 5 wires attached.
3. Set the ground lug aside. It will not be re-used. Re-install the nut and bolt removed in step 1, without the ground lug, to fasten the leg of C12 to the chassis.
4. Cut the black wire that connects to C12's negative terminal to a length of 1 inch. Slide the insulation off, leaving 1" of bare wire connected to the terminal.
5. Connect the black wire from Q9's collector on the power supply to C12's negative terminal. C12's negative terminal now has two wires, the wire from Q9's collector, and a 1" long bare wire.
6. Connect the wire from C11's negative terminal to the bare wire on C12's negative terminal, at the end closest to the terminal.

Revise the Power System

Warning: Do not connect power to the amplifier modules unless you are sure that the power supply output voltage is less than 76 Volts!

1. There are three red wires connected to C12's positive terminal:
 - a. From PC-11 eyelet 4
 - b. A long unconnected wire that used to go to the right channel
 - c. A shorter unconnected wire that used to go to the left channel
2. Cut the shorter wire to 1" length and remove the insulation.
3. Remove the wire dangling from C11's positive terminal. Connect the longer wire from C12's positive terminal to C11's positive terminal.
4. Cut the supplied 24" length of red-black wire into two 12" lengths.
5. For the first 12" piece, remove 1/2" of insulation from the red and black wires at one end.
6. Repeat this for the second 12" piece of red and black wire.
7. Wrap the red wire of the first red-black wire around the bare wire that connects to C12's positive terminal, closest to the terminal.
8. Wrap the red wire of the second red-black wire around the bare wire that connects to C12's positive terminal, next to the previous wire.
9. Wrap the black wire of the first red-black wire around the bare wire that connects to C12's negative terminal, closest to the terminal.
10. Wrap the black wire of the second red-black wire around the bare wire that connects to C12's negative terminal, next to the previous wire.
11. Strip 1/2" of insulation from one end of the 18 AWG stranded wire supplied with the kit. Wrap this around the bare wire that connects to C12's negative terminal, next to the previous wire.
12. Solder all the wires on C12.

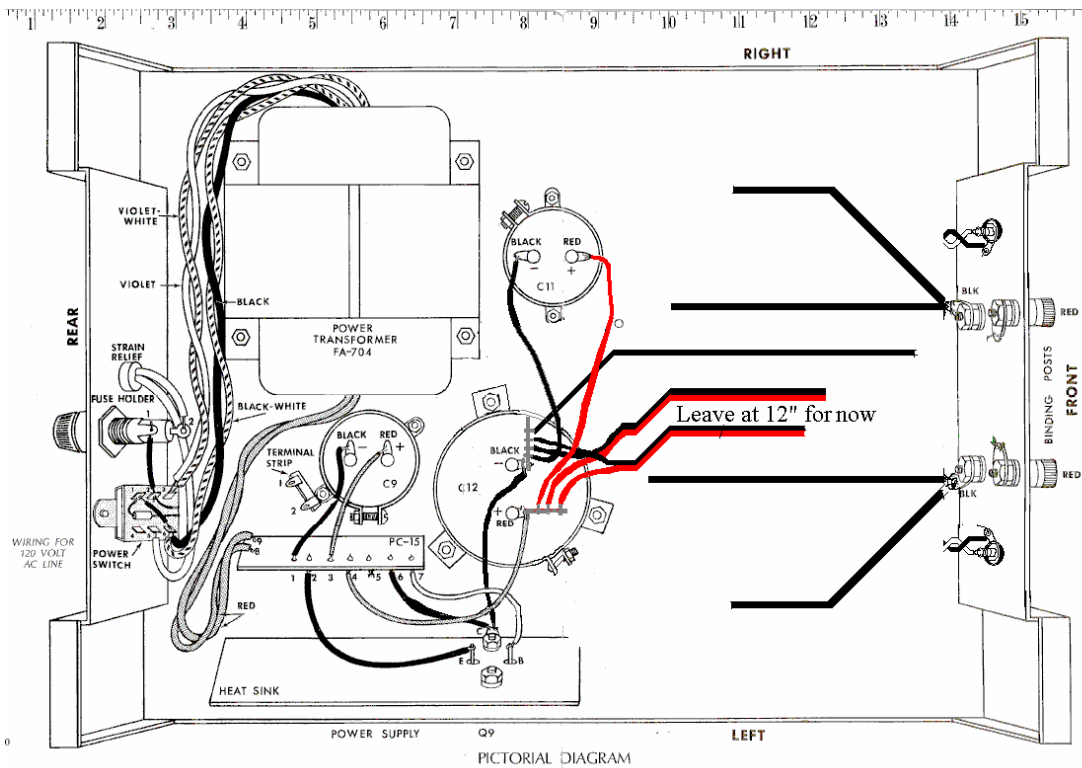

Figure 20-Rewiring the Power and Half the Grounds

Complete the Ground System

Please refer to Figure 21. It shows how the completed wiring will look.

1. Locate the centrally located hole in the chassis nearest the input/output panel. It previously was used for an output capacitor mounting bracket. We will locate a star-ground lug in that hole, fastened with a 6-32 screw and nut. Don't screw the lug down at this time.
2. Connect these three wires to the ground lug. Cut their lengths to fit comfortably.
 - a. The black wire from C12's negative terminal.
 - b. The shorter black wire from the right channel speaker binding post.
 - c. The shorter black wire from the left channel speaker binding post.

Wiring the Inputs

Note: These directions assume that you are using the original, non-isolated RCA jacks. These jacks make a ground connection to the chassis. If you are using isolated RCA jacks, or if your RCA jacks are original jacks held in with rivets and the rivets are loose, then you must add the two wires shown in Figure 23.

1. Right Channel – Remove the old wires from the input connector.
 - a. Take one black-white twisted pair and cut it to a 4" length⁷.
 - b. Strip ¼" of insulation off both sides of the two wires.

⁷ This may seem a bit long to you, but lets you position the modules for inspection or re-work without unsoldering the input wires. Feel free to make these wires shorter once you are comfortable with the amplifier's performance.

2. Connect the black/white twisted pair to the right channel input jack.
 - a. Solder the black wire to the shorter terminal (ground).
 - b. Solder the white wire to the longer terminal
3. Left Channel – Remove the old wires from the input connector.
 - a. Cut the second black-white twisted pair to a 5.5” length.
 - b. Strip ¼” of insulation off both sides of the two wires.
4. Connect the black/white twisted pair to the Left channel input jack.
 - a. Black wire to the shorter terminal (ground)
 - b. White wire to the longer terminal

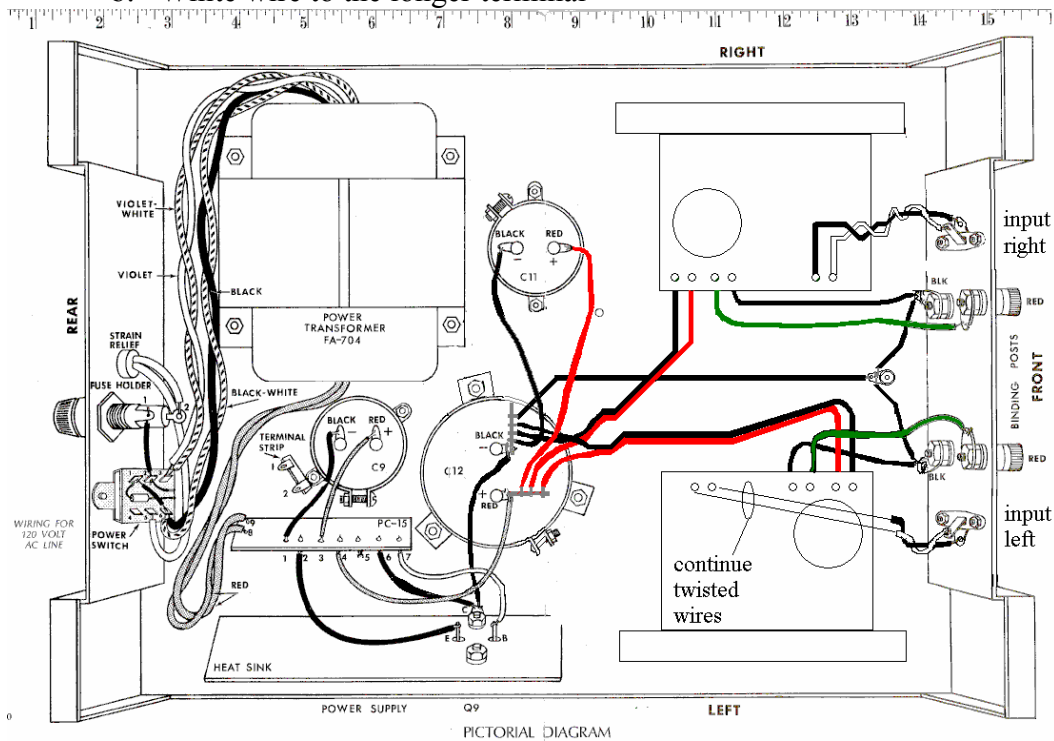

Figure 21-completed wiring

Wiring the Outputs

Both red speaker output terminals should have 16 AWG white wires still connected. (For clarity, this is shown in green in Figure 21.)

1. Form the left channel wire toward the place where the left channel amplifier module will sit.
2. Form the right channel wire toward the place where the right channel amplifier module will sit.

Connecting the Left Channel Amplifier Module

1. Set the left channel amplifier board and heat sink assembly in place. Don't mount it to the chassis yet. Note that the new PCB should face the center of the amplifier chassis.
2. Select one red-black pair connected to C12 to power the left channel board:
 - a. From the solder side of the board, insert the left channel red wire through the left channel VCC eyelet and solder it on the component side.

- b. From the solder side of the board, insert the left channel black wire through the left channel PGND eyelet and solder it on the component side.
3. For the black and white twisted pair that brings signal to the left channel board:
 - a. From the component side of the board, insert the left channel black wire through the left channel INGND eyelet and solder it on the solder side.
 - b. From the component side of the board, insert the left channel white wire through the left channel INPUT eyelet and solder it on the solder side.
4. Dress the remaining black wire coming from the left channel black speaker binding post to one of the OGND terminals of the left channel amplifier. Cut it to length and remove $\frac{1}{4}$ " of insulation. Insert it into the OGND terminal from the solder side of the board, and solder it on the component side of the board.
5. Dress the white wire from the left channel red speaker binding post to the OUT eyelet of the left channel amplifier. Remove $\frac{1}{4}$ " of insulation, and insert the wire from the solder side. Solder on the component side.
6. Check your work. The following eyelets on the PCB should each have a wire:
 - a. VCC (red wire of the red-black pair)
 - b. PGND (black wire of the red-black pair)
 - c. IGND (black wire of the black-white twisted pair)
 - d. INPUT (white wire of the black-white twisted pair)
 - e. OGND (black wire from the left channel black speaker binding post)
 - f. OUTPUT (wire from the left channel red speaker binding post).
7. Make sure that the bottom lip of the heat sink is clean, and also the place where it mounts to the chassis. Place a line of thermal compound along the bottom of the short part of the heat sink. Smear it into a thin film using a finger.
8. Mount the heat sink to the chassis using salvaged 6-32x $\frac{1}{2}$ " hardware. Remember that the outside mounting screw also carries a mounting foot.

Connecting the Right Channel Amplifier Module

9. Set the right channel amplifier board and heat sink assembly in place. Don't mount it to the chassis yet. Note that the new PCB should face the center of the amplifier chassis.
10. Select one red-black pair connected to C12 to power the right channel board:
 - a. From the solder side of the board, insert the right channel red wire through the right channel VCC eyelet and solder it on the component side.
 - b. From the solder side of the board, insert the right channel black wire through the right channel PGND eyelet and solder it on the component side.
11. For the black and white twisted pair that brings signal to the right channel board:
 - a. From the component side of the board, insert the right channel black wire through the right channel INGND eyelet and solder it on the solder side.
 - b. From the component side of the board, insert the right channel white wire through the right channel INPUT eyelet and solder it on the solder side.
12. Dress the remaining black wire coming from the right channel black speaker binding post to one of the OGND terminals of the right channel amplifier. Cut it to length and remove $\frac{1}{4}$ " of insulation. Insert it into the OGND terminal from the solder side of the board, and solder it on the component side of the board.

13. Dress the white wire from the right channel red speaker binding post to the OUT eyelet of the right channel amplifier. Remove ¼” of insulation, and insert the wire from the solder side. Solder on the component side.
14. Check your work. The following eyelets on the PCB should each have a wire:
 - a. VCC (red wire of the red-black pair)
 - b. PGND (black wire of the red-black pair)
 - c. IGND (black wire of the black-white twisted pair)
 - d. INPUT (white wire of the black-white twisted pair)
 - e. OGND (black wire from the right channel black speaker binding post)
 - f. OUTPUT (wire from the right channel red speaker binding post).
15. Make sure that the bottom lip of the heat sink is clean, and also the place where it mounts to the chassis. Place a line of thermal compound along the bottom of the short part of the heat sink. Smear it into a thin film using a finger.
16. Mount the heat sink to the chassis using salvaged 6-32x1/2” hardware. Remember that the outside mounting screw also carries a mounting foot.

Making the Speaker Binding Posts User Friendly

The speaker binding posts have holes for the speaker wire. These holes should be oriented from side to side, not up and down, to allow easy connection of the speaker wires. If your binding posts are already correctly oriented, skip this step. If not, here’s the procedure that should be applied to whichever of the 4 binding posts don’t have the correct orientation:

1. Loosen the binding post (red or black plastic part) until you can see the hole in the mounting stud.
2. Loosen and remove the nut that holds the speaker connection wires. Remove the speaker wire lugs, noting their locations so that they may be correctly returned.
3. Loosen the remaining nut just enough to be able to spin the binding post to the correct orientation. Keep the binding post from turning as you tighten it with a nail (or stout toothpick) through the wire hole.
4. Replace the solder lugs with the speaker connection wires.
5. Replace and tighten the nuts that hold those lugs in place.

Section 6: Testing the Completed Amplifier

It’s best to test the completed amplifier one step at a time. In that manner, if you have something wrong, you may damage the amplifier module, but you won’t damage your speakers.

Test #1

1. Disconnect signal inputs and speakers from the amplifier.
2. Turn the power switch off.
3. Plug in the amplifier.
4. Turn the power switch on.
5. Observe the amplifier for a minute.
 - a. It will make a “bong” sound when you turn on the power switch, but after that about all you should hear is a soft humming sound from the power transformer.

- b. Watch for smoke. There should be no smoke. If you see smoke, turn off the amplifier immediately, take a few deep breaths, and refer to the troubleshooting section.
 - c. Feel the heat-sinks. There should be no appreciable heating.
6. In a normally lit room, you should see that both LEDs are on.

If this all goes well, (no smoke or excess heating) leave the power on and move on to Test #2.

Test #2

1. If you have a DC voltmeter, check the voltage on the speaker outputs.
 - a. Left channel red to black binding post should show a DC voltage of less than 100 mV if the amp has been on for about 1 minute⁸. The longer the amp is on, the lower the DC output voltage will be.
 - b. Repeat this test for the Right channel speaker binding posts.

If this result is ok, go on to test 3. If this result is not correct (e.g. speaker binding posts have a few volts of DC after the amp has been on for more than 1 minute), then re-check:

- Polarity of C7
- R17 is installed and has the correct value (1000 Ohms)
- That one of the OGND terminals has a ground wire installed.

Test #3

1. Hook speakers up to the binding posts. There may be a very soft click as you hook up the speaker.
2. The speakers should be rather quiet at this point, perhaps with barely audible hiss or hum if you place your ear near sensitive speakers. Any more noise than this probably indicates either an assembly error or a power supply problem.

Test #4

1. Turn off the amplifier power.
2. Connect your preamp output to the power amplifier input.
3. Turn down the preamp volume.
4. Turn on the amplifier power. You may hear a soft click or thump from your speakers.
5. After about 15 seconds, turn up you preamp volume to the desired listening level, and enjoy your amplifier.

The amplifier has special slow turn-on features that avoid pops and clicks in the speakers at turn-on without the need for relays. The DC bias voltages in the amplifier will thus take 30 seconds or so to reach steady state. During that time, you may hear some distortion. Don't worry, it will clear up perfectly in 30 seconds unless you are over-driving the amp, or something is wrong. Think of it like a tube amp...it takes 30 seconds to warm up.

⁸ The DC voltage will drop to very nearly zero in 15 seconds if a speaker is connected.

All resistors 1/4W, 1% unless otherwise noted

GT-101 Amplifier Module
 As configured for use in TCK amplifier
 modules for the Dynaco Stereo 120
 Copyright 2012, 2013 Akitika LLC
 All Rights Reserved
 U1 is LM3886 with
 non-isolated case

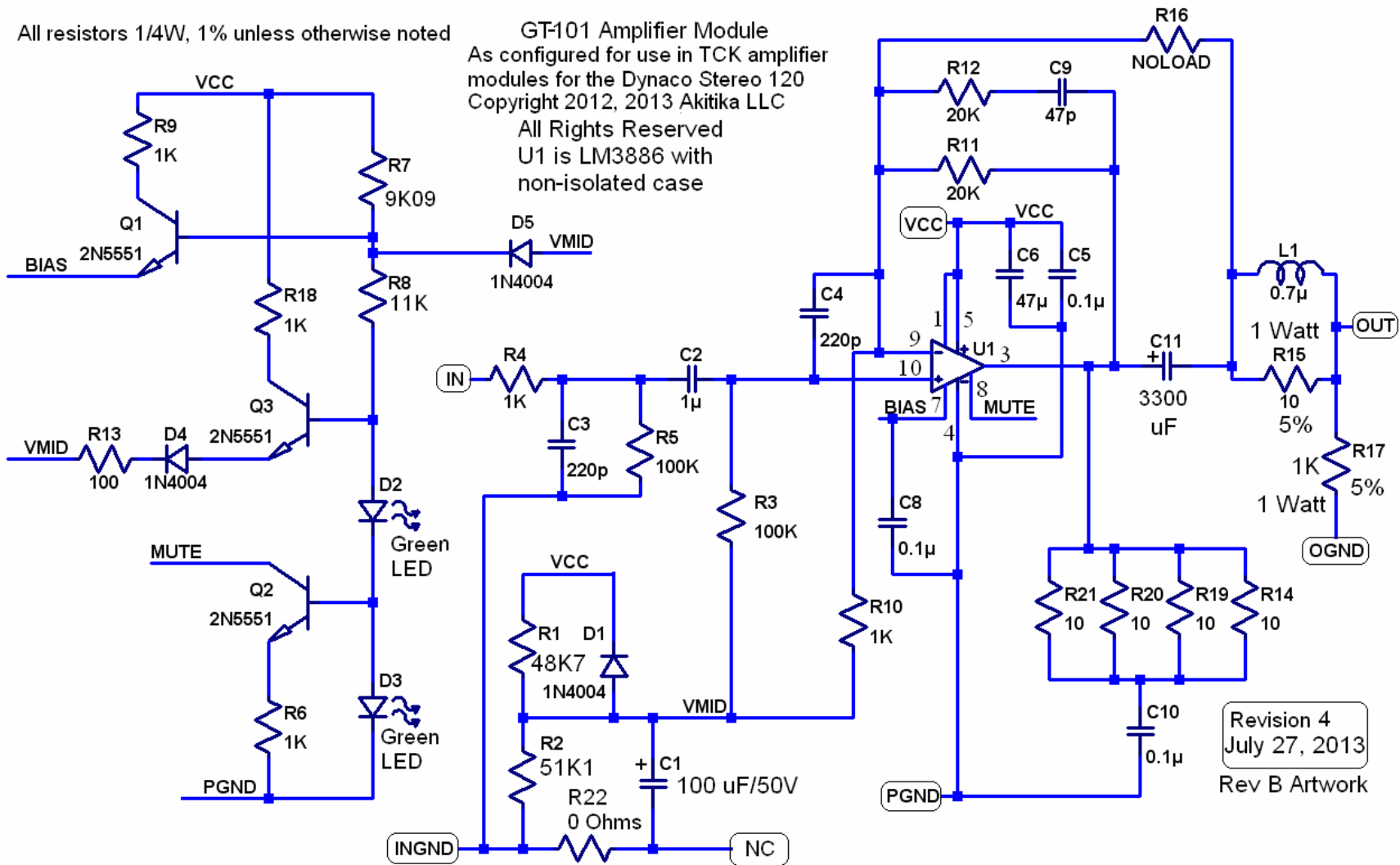
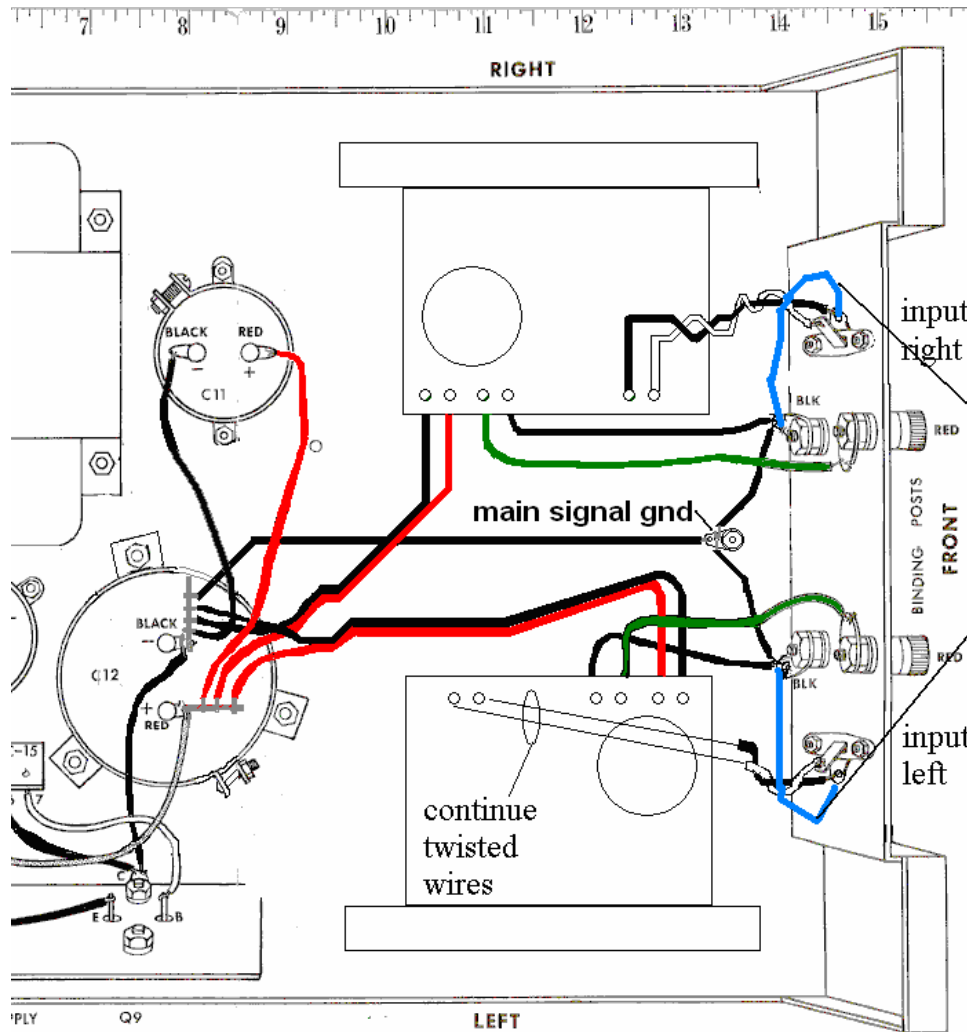

Figure 22-Schematic of amplifier module



PICTORIAL DIAGRAM

add these ground wires if:
 1. you're using insulated ground RCA jacks, or
 2. you have original jacks retained by rivets, and the rivets are loose, or
 3. you have any doubt about the quality of the connection of the RCA connectors to the main signal ground.

Figure 23-Optional Input Ground Wires are shown in blue

Resistor Color Code



Figure 24-demonstrating the resistor color code

Here's an extreme close-up of a $\frac{1}{4}$ W metal film 20K (20,000) Ohm resistor, designated by the standard resistor color code.

The colors map to numbers:

Color	Number
Black	0
Brown	1
Red	2
Orange	3
Yellow	4
Green	5
Blue	6
Violet	7
Gray	8
White	9

The color band positions have the following meaning (5-band, 1 % resistors):

Position	Meaning
1	Left-most Digit (e.g. most significant)
2	Next digit to the right
3	Next digit to the right.
4	Number of zeros that follow the three digits, unless: <ul style="list-style-type: none"> • Band 4 is gold => multiply by 0.1 • Band 4 is silver=> multiply by 0.01
5	Tolerance: <ul style="list-style-type: none"> • Brown =>1% • Red => 2% • Gold=> 5% • Silver=>10% • No band=>20%